



Selection Guideline

For

Insulated Metal Panels

Copyright © 2017 Metal Construction Association. All rights reserved.

No part of this publication may be reproduced in any form or by any means, including photocopying, or utilized by any information storage or retrieval system without permission of the copyright owner.

TABLE OF CONTENTS

SECTION 1: ASSOCIATION BACKGROUND	4
SECTION 2: INTRODUCTION	4-9
What Are Insulated Metal Panels and How Are They Manufactured?	4
How Do IMPs Compare to Other Systems?	4-5
Why Choose Insulated Metal Wall and Roof Systems?	5-6
Where Are Insulated Metal Panels Used?	6
Performance Criteria.....	7
Panel Thickness Variation	8
R Value Comparison	8
Panel Selection	8-9
Finish Selection	9
SECTION 3: PRODUCT TESTING AND CERTIFICATION	10-11
Fire	10
Structural	10
Listings	10
Thermal Transmittance	11
Core Physical Properties	11
Water Penetration	11
Air Infiltration	11
SECTION 4: PRODUCTION PROCESS	12-14
Product Description	13-14
SECTION 5: DESIGN PARAMETERS	15-16
Thermal Effects	15
Metal Roof End Laps	15
Metal Roof Slope	16
Metal Roof Penetrations	16
SECTION 6: INSTALLATION	17-20
Support Gauge and Alignment	17-18
Panel Layout	19
Panel Trim	19
Panel Clips and Fasteners	19
Panel Caulking and Sealants	19
Summary	20
SECTION 7: DETAIL ILLUSTRATIONS	21-27
Vertical Panel Details	21-24
Horizontal Panel Details	25
Roof Panel Details	26-27
ADDENDUM 1: Features and Benefits	28
ADDENDUM 2: Insulated Metal Panel Guide Specifications Bullets	29-30

Disclaimer

This Guideline is for general information only. It is designed to highlight areas requiring consideration. Information contained in the Guideline should not be used without first securing competent advice concerning application suitability for any given building project. MCA does not assume responsibility and disclaims any representation or warranty, express or implied, that such information is suitable for any general or particular use. Anyone making use of this Guideline assumes all liability resulting from such use.

The existence of this Guideline does not in any respect preclude a member or non-member of MCA from manufacturing, selling or specifying products not conforming to the Guideline, nor does the existence of an MCA Guideline preclude its voluntary use by persons other than MCA members. This Guideline does not purport to address all safety problems associated with its use or all applicable regulatory requirements. It is the responsibility of the user of this Guideline to establish appropriate safety and health practices and to determine the applicability of regulatory limitations before use of the Guideline.

The Metal Construction Association reserves the right to change, revise, add to, or delete any data contained in this manual without prior notice.

INSULATED METAL PANEL (IMP) WALL AND ROOF SYSTEMS

SECTION 1: ASSOCIATION BACKGROUND

The Metal Construction Association (MCA) was formed in 1983 as a non-profit organization. The primary purpose of the Association is to promote the wider use of metal in construction. MCA unites diverse industry segments for this common purpose. One of these segments is Insulated Metal Panels.

SECTION 2: INTRODUCTION

What Are Insulated Metal Panels and How Are They Manufactured?

Since the 1960s, contractors and designers of commercial, industrial and refrigerated buildings have relied on Insulated Metal Panels (IMP) for their aesthetics, excellent thermal efficiency, ease of installation and overall structural integrity. IMPs in their most general form are rigid insulation sandwiched between two facings of coated metal. IMPs are molded in a variety of styles and sizes depending on application. Steel or aluminum panel facings create an air, water and vapor barrier. The facings are resistant to abuse and come in a multitude of finishes, effects, and colors. IMP cores can be made of either foam plastic or mineral fibers. Foam cores can be either foamed-in-place or laminated. The most common IMPs on the market are foamed-in-place.

Foam is injected, as a liquid or froth, between the sheets of metal. The foam undergoes a chemical reaction causing it to rise and bond to the metal skins, filling the interior cavity, creating a solid monolithic panel that maintains a consistent thermal value and resists moisture, insect and rodent infiltration. IMPs can also be manufactured by a laminating process. In this method, pre-cured foam board stock is adhered to preformed metal facings with structural adhesives and placed under pressure in a platen press operation. With both types of IMPs a factory controlled, uniform foam thickness provides consistent insulation performance. Mineral wool panels are manufactured using a process similar to laminated foam panels.

How Do IMP Systems Compare To Other Systems?

IMP systems provide many of the same benefits and features found with other metal wall and roof systems plus some unique benefits found only with “foam” panels. IMPs are complete factory assembled wall or roof units consisting of the exterior cladding, insulated/structural core and interior liner. Units are finished and ready to erect and seal together upon delivery. Multiple construction trades are not required for installation. IMP systems are installed as a single element allowing for faster building completion in almost any kind of weather without risk to system integrity, as opposed to multiple installation steps for other insulated wall and roof systems.

The wall and roof panels are available in a wide range of long lasting finishes and colors. When combined with the inherent benefits of metal facings, IMPs require less maintenance than other exterior systems and meet the most demanding performance requirements.



© 10/17 Selection Guide for Insulated Metal Panels | V2

METAL CONSTRUCTION ASSOCIATION

8735 W. Higgins Road, Suite 300, Chicago, IL 60631

847.375.4718 | mca@metalconstruction.org | www.metalconstruction.org

BUILD LEGACIES
METAL

IMPs offer high insulation values and built-in thermal breaks that provide better insulation performance than field assemblies to the building owner. Water, vapor and air barriers are easily achieved through the tongue and groove joining of the metal panel facings and thermal performance is enhanced, since there is no metal conductance from exterior to interior facings.

On large commercial and industrial facilities, as shown on this and the following pages, IMP wall systems erect very quickly. Structures such as cold storage facilities, hangars, manufacturing plants, food processing facilities, office buildings and convention centers are proven to be excellent applications. On these projects, under normal wind conditions, support girt spacing in the 6-10 foot range is used to take advantage of the high panel strength. Metal facings are commonly manufactured from 22, 24 and 26 gauge metal skins used with profiled or striated patterns to minimize the material cost while maintaining the structural integrity and product flatness.

Architecturally, IMPs also offer many design features. Joint size variations, joint reveal widths, curved and formed panels, formed corner panels, end folds and treatments, heavier gauge flat facings and high performance coatings are only a few of the more common design features. These products have also been used as components in high performance curtain walls and have been successfully tested in large job specific mockups.

When compared to other product options in both metal and non-metal, insulated metal wall and roof systems offer a **cost competitive – high performance system** that answers today's demands for quick building enclosure at a low cost while offering a wide range of design and performance features. These panels have been successfully used in a variety of non-residential markets from large light industrial/warehouse buildings and freezer-cooler applications to complex high tech architectural applications.

This guideline introduces the product; covers manufacturing and performance criteria; provides product application items, a feature-benefits summary, points for a guide specification and sample details.

Why Choose Insulated Metal Wall and Roof Systems?

There are benefits for all parties involved in the building enclosure as shown in the Features and Benefits List in Addendum 1. The designer has a myriad of design options ranging from flat to profile panels, color, texture, panel width, joint size options and joint orientations. The designer can also choose product performance options ranging from panel insulation value to span length to load/span capability. The erector has a lightweight product that erects quickly vs. conventional construction in response to fast-track schedule demands. Also, the weight difference offers framing and foundation savings particularly in high seismic areas. The owner gets a highly energy efficient building envelope with lower heating and cooling costs.



© 10/17 Selection Guide for Insulated Metal Panels | V2

METAL CONSTRUCTION ASSOCIATION

8735 W. Higgins Road, Suite 300, Chicago, IL 60631

847.375.4718 | mca@metalconstruction.org | www.metalconstruction.org

BUILD LEGACIES
METAL

Erection efficiency with IMPs is higher than with other products because it is less affected by weather and the owner gains a high performance system at one of the best life cycle costs of any product available today.

Erection speed is the key to many projects today. Depending on job complexity and size, IMPs can be erected at a rate of up to 5,000 sq. ft. per 8-hour shift by a four-man crew on an industrial project and up to 1,100 ft²/8-hour shift by a four-man crew on an architectural project when proper lifting equipment is used. Higher installation rates can be achieved with insulated metal roof panels.

Another primary feature is the advantage of pre-painted metal, which offers factory applied high performance finishes in a wide palette of colors. These corrosion resistant, high performance polymeric coatings can extend the life cycle of the product making IMPs better than many other exterior system options. Interior coatings provide easy cleaning and washing as well as high light reflectivity. Each of these attributes is critical in food processing facilities.

When compared to stucco, masonry or pre-cast for walls and built-up, modified bitumen or EPDM for roofs, the advantages of the impermeable exterior and interior metal facings of IMP stands out.

When compared to other materials, which are field assembled or applied, IMPs minimize the erector impact on the system performance. This results in better in-place quality, better weather integrity and appearance. Having many of the components combined into one offers the best in-place quality and erection speed.

Where Are Insulated Metal Panels Used?

IMPs are used in a large number of commercial, industrial, institutional and cold storage applications because of their excellent performance characteristics and competitive in-place costs. Generally, the market is subdivided into three areas: Cold Storage (CS); Institutional, Commercial and Industrial (ICI) and Architectural. Key product differences that distinguish the markets are as follows:

- CS – Panel thickness > 4”, usually vertical profiled skins, lowest cost per unit R-value.
- ICI – Panel thickness 2”-4”, usually vertical lightly profiled panels, intermediate cost per unit R-value.
- Architectural – Panel thickness 2”-4”, usually horizontal lightly profiled or flat panels, highest cost per unit R-value.

Examples of these markets include:

- Airport hangars (ICI)
- Bank buildings (ICI & Architectural)
- Churches (ICI & Architectural)
- Manufacturing buildings (ICI)
- Offices (ICI & Architectural)
- Sports facilities (Architectural)
- Distribution centers (ICI)
- Schools and universities (ICI & Architectural)
- Food storage and processing facilities (CS)
- Sub-freezing storage facilities (CS)

Performance Criteria

IMPs are manufactured to meet the performance and testing requirements of the building codes and insurance listing agencies. IMPs are tested for fire, structural, thermal transmittance/resistance, foam core properties, water leakage and air pressure differential. In some cases, an additional thermal barrier may be required on the inside of these panels for certain construction conditions. Consult the locally accepted building code and the IMP manufacturers for further information.

For most applications, full-scale tests must be conducted to indicate the in-place performance of the product in a fire. These tests include small- and large-scale room corner tests conducted at independent testing agencies such as Underwriters Laboratories, Intertek and FM Approval that are required for IBC compliance, as well as multistory testing (NFPA 285). Before specifying an IMP, a manufacturer must be requested to demonstrate the product's compliance with an array of fire tests as described in the International Building Code (IBC).

Properly certified IMPs may be used where non-combustible materials are required by the code subject to certain limitations. **Be sure the product selected meets the requirements of the controlling code for a given project and a given location.**

Insulated metal wall and roof panel designs are verified by representative structural tests for positive and negative wind loads. Manufacturers should provide calculations verifying that all factors affecting the load carrying capacity of the panels have been analyzed and that they meet the project requirements.

Foam cores are subjected to a series of physical performance tests to determine the strength and aging characteristics of the material. Foam is measured for (1) density, (2) shear strength, (3) tensile strength, (4) compressive strength, (5) humidity aging, (6) heat and cold aging (7) insulating efficiency, (8) aging stability and (9) flash and ignition properties. Complete assemblies are tested to determine that there is no uncontrolled water or air leakage at required pressure differentials. See Section 3 of the Guideline for specifics of testing and certification relating to these criteria.

One of the main features of IMPs is the thermal performance. Thermal performance is generally described in one of two ways: Foam core R-value and panel assembly thermal transmittance or U-factor. It is very important to understand the differences between these two.¹

Foam core R-value is generally determined by ASTM C 518, which gives the R-value of the foam core only. This number does not generally account for joint or framing effects or gap resistances.

Panel assembly U-factor is determined by a hot box test (usually ASTM C 1363) and does account for the joint effects and gap resistances. It also generally includes air-film resistances.

IMPs have a foam core that provides R-values generally ranging from 7 to 48 as thickness goes from 1-6" for wall systems and R-values ranging from 10 to 48 for roof systems as thickness goes from 1½-6".

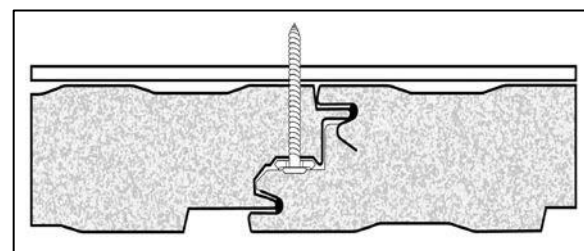

¹ It is important to note that R-value and U-factor should not be compared by using the heat transfer equation $R=1/U$ unless the user is assured that the input R-value and U-factor are compatible in test method, specimen configuration and inclusion of air film effects.

IMP U-factors are generally available from the manufacturer's website. The test specimen includes a panel side joint to account for any thermal inefficiency that may occur. Most products perform very well because the side joints of virtually all panel designs have a natural thermal break between the outer and inner metal facings.

Panel Thickness Variations

These products offer more than twice the insulation efficiency as a field assembled glass fiber system. The table below summarizes the R-value per inch for many common insulation materials. As shown in this table, Polyurethane/Polyisocyanurate (PUR/PIR) insulation is the most efficient when looking at R-value alone. Remember also that insulation placed in a stud cavity is less effective due to the thermal bridging. Therefore, one must consider U-factor, not R-value, to make an apples-to-apples comparison of traditional assemblies to IMPs.

R Value Comparison

Insulation Type *	R Value/1"
Extruded Polystyrene	5
Expanded Polystyrene	4
Mineral Fiber	3
Cellular Glass	3
PUR/PIR (Initial)**	7.5
PUR/PIR (Aged)**	6.5
*Source: Society of Plastics Industry ** Thermal loss over time usually lowers	

As an example, consider a metal framed wall assembly in Climate Zone 5 under IECC 2015. The baseline assembly is R-13 fiberglass in a 4" stud wall cavity insulation plus R-7.5 continuous insulation for a maximum U-factor of 0.064 Btu/hr-sf-F. (R-15.6) Assuming polyisocyanurate for the continuous insulation (R-6.5/in), this results in a total insulation thickness of nominally 5". (4" glass fiber plus 1" PUR/PIR) Compare this to a 2½" IMP which may have a U-factor quite a bit lower (better) than 0.064 Btu/hr-sf-F. For many buildings, this will translate to more usable floor space for the same out-to-out dimensions.

IMPs are very strong structurally due to the composite action between the flat facings and the foam core. For a 2 inch panel, most wind load requirements in the 20 to 30 psf ranges can be met with 7 to 10-foot span conditions. Panel capacity is often controlled by the fastener system capabilities under negative wind loads. **Check the negative load performance when using load span data for any product.** Also, note that IMPs are not typically designed for use as bearing walls or shear diaphragm walls.

(IMP installations should always be designed by a registered design professional to show conformance with the requirements of the local building code.)

Panel Selection

The primary variable in the selection of an IMP is the thickness needed to meet the required thermal value. After the thermal value is determined, a review of the structural span tables is necessary to ensure that the panels in the thickness selected will meet the structural requirements. Narrow panels are generally stronger considering negative (uplift) loads because there are more fasteners per square foot panel area.

The most common substrates for IMPs are G90 galvanized (ASTM A653) steel, AZ 50 or AZ 55 aluminum-zinc alloy coated (ASTM A792) steel, and aluminum for both the interior and exterior facings. Heavier combinations of gauges for both interior and exterior facings are available depending on requirements for load/span capability, resistance to abuse, and aesthetic needs.

Finish Selection

Insulated metal wall and roof panels are typically prefinished on both the interior and exterior facings. The typical exterior finish is the industry standard nominal 1 mil (inclusive of primer) PVDF (70% Kynar[®] 500/Hylar[®] 5000). A silicone modified polyester paint is commonly used as the exterior finish on cold storage buildings.

The typical interior finish is a nominal 0.8 mil (inclusive of primer) standard polyester, in a light reflective, easy to maintain white color. USDA approved finishes are also available where required for food processing and storage.

Special high build coatings, such as plastisols, are available on both the interior and exterior facings of the panels to provide added protection in extreme environments.

SECTION 3: PRODUCT TESTING AND CERTIFICATION

The following testing requirements go a long way towards ensuring the designer and owner that they are getting an assembly that will meet or exceed the requirements of the appropriate building codes and the requirements of insurance agencies, such as FM Approvals. All major insulated panel manufacturers can meet the performance requirements listed below. These certifications may also qualify all of the included wall or roof components (exterior cladding, insulating/structural core, interior liner, connections and seals) as a complete wall or roof assembly in a single document. This eliminates the customer's need to qualify each component and the need to qualify that these different components work together as a job specific construction, which often requires testing for each specific assembly or at least an in depth engineering analysis of the proposed assembly.

Fire

To conform to the requirements of the major building codes, primarily the International Building Code (IBC) IMPs should be tested by Underwriters Laboratories, Intertek, FM Approvals or similar testing and listing agencies. The foam core should have a maximum flame spread of 25* and a maximum smoke developed index of 450* when tested in accordance with ASTM E84 (UL 723). Compliance with the requirements of ASTM E108 (UL 790) with recognition as a Class A, B, or C roofing assembly is generally required for roof applications. For wall applications, conformance to the performance requirements of NFPA 285 is also required for most applications. Full scale corner tests such as NFPA 286, UL 1040 or UL 1715 are also required in certain instances depending on the application. Testing such as FM Global 4880 may also be required for insurance purposes on highly protected risk (HPR) facilities.

**These numerical Flame Spread and Smoke Developed indexes do not define the hazard presented by this or any other material under actual fire conditions.*

Structural

Structural load capacity should be verified by representative structural tests for positive as well as negative wind loads as shown in testing such as ASTM E72, ASTM E330, UL 1897 or ASTM E1592 for wind load resistance of IMP assemblies. The maximum allowable deflection is defined in Table 1604.3 of the IBC (2015). The local building code should be referenced for the applicable limiting criteria. The effects of snow load and long-term loads on roof panels should be considered as appropriate in the structural analysis.

Compliance with the structural provisions of the code can be shown in two ways. Either the IMP manufacturer will provide calculations sealed by a professional engineer verifying that all factors affecting the load carrying capacity of the panels have been analyzed and verified by testing and that the structural capacity of the panels meets the project requirements, or the IMP manufacturer will provide sufficient documentation to the Engineer of Record (EOR) demonstrating this performance. In the latter case, an evaluation report from a third-party agency such as ICC-ES or IAPMO showing compliance with AC04 is normally utilized.

Listings

When required for insurance purposes insulated metal roof panels should be tested to determine load capabilities by an independent testing agency, such as Underwriters Laboratories or FM Approvals, and ratings similar to the following:

- Underwriter's Laboratories Wind Uplift – UL 580 typically Class 60 or 90.
- FM Approvals – FM 4471 – Typically, 1-60, 1-75 or 1-90.

Thermal Transmittance

The completed panel assembly, including side joints, should be tested in accordance with ASTM C1363 at 75°F for normal building applications. A 40°F mean test temperature is commonly used for refrigerated buildings. IMPs are available with thermal transmission values generally ranging from U-0.08 to U-0.02. Thermal values should be specified based on local energy code requirements, desired operating efficiency, usage, and occupancy.

Core Physical Properties

The polyurethane or polyisocyanurate core tests include:

- Density (ASTM D1622)
- Closed Cell Content (ASTM 2856)
- Shear strength (ASTM C273)
- Tensile strength (ASTM D1623)
- Compressive strength (ASTM D1621)
- Humidity, Heat, Cold Aging (ASTM D2126)

The IMP core properties will vary slightly with the type of foam that each manufacturer uses. The most critical factor in panel production is formulating a foam system with the right balance of these properties that will ensure structural integrity and adhesion of the foam to the metal facings.

Water Penetration

A complete panel assembly mounted vertically containing panel side joints should be tested in accordance with ASTM E331 and should exhibit no uncontrolled water leakage at a minimum of 6.24 psf air pressure differential for 2 hours for wall panel assemblies (IBC 1403.2) and in accordance with ASTM E1646 with no uncontrolled water leakage through the panel joints at a static pressure of 12 psf for roof panel assemblies.

Air Infiltration

A complete panel assembly containing at least one principal panel side joint should be tested in accordance with ASTM E283. Air infiltration should not exceed 0.04 cfm/sf at 1.56 psf air pressure differential for wall panel assemblies and in accordance with ASTM E1680 at a static pressure of 1.56 psf for roof panel assemblies to show compliance with the requirements of IBC (2015).

SECTION 4: PRODUCTION PROCESS

The process of manufacturing IMPs requires a marriage of customized mechanical equipment and foam chemistry. The most involved is the continuous process as shown in Figure 1. Greatly simplified, it entails forming the continuous metal facings while at the same time (at another point on the continuous line) injecting the foam mixture into the panel assembly. The foam then expands and fills the cavity between the metal facings as they enter a platen conveyor. The conveyor ensures that proper temperature and pressure are maintained during foam gel time. Panels are then cut to length with an in-line cross cut saw. Post fabrication work, available through some manufacturers, can be performed on the product to treat the cut ends of the panels or standing seams in the case of roof panels.

Figure 1. Schematic of continuous manufacturing process for insulated metal panels

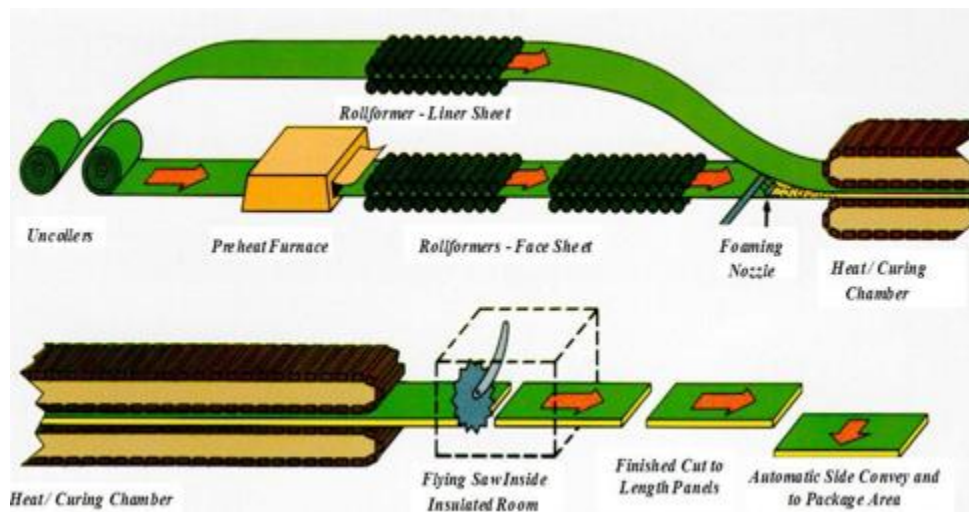

IMPs can also be manufactured by a laminating process as shown in Figure 2. In this method, procured foam board stock in an appropriate thickness is adhered to preformed metal facings with structural adhesives and placed under pressure in a platen press operation.

Figure 2. Schematic of laminating process for manufacturing insulated metal panels.

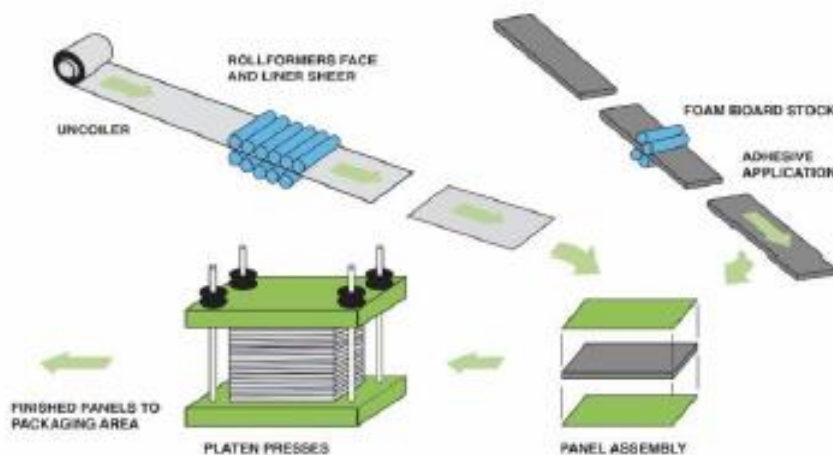

Product Description

The most common metal substrate for painted panel facings is G90 galvanized steel. Other substrates are stainless steel, aluminum-zinc coated steel, and aluminum. To stiffen the panel facings an embossed surface texture is commonly applied and various profiles are roll formed into the panels. Profiles are usually in the form of light striations or planking, deep ribbing or stiffening beads. Smooth or un-embossed surfaces are available as a premium from some manufacturers.

Panel edges are roll formed to create interlocking side joints, which accommodate the concealed fastener and clip system and achieve the panel-to-panel seals. A variety of modules, profiles and side joints are available for insulated metal roof systems. For example, side joints can be standing seam, or overlapping as shown in Figure 3. The width of the panel is referred to as the module and typically ranges from 24-42”.

Figure 3. Examples of side joints

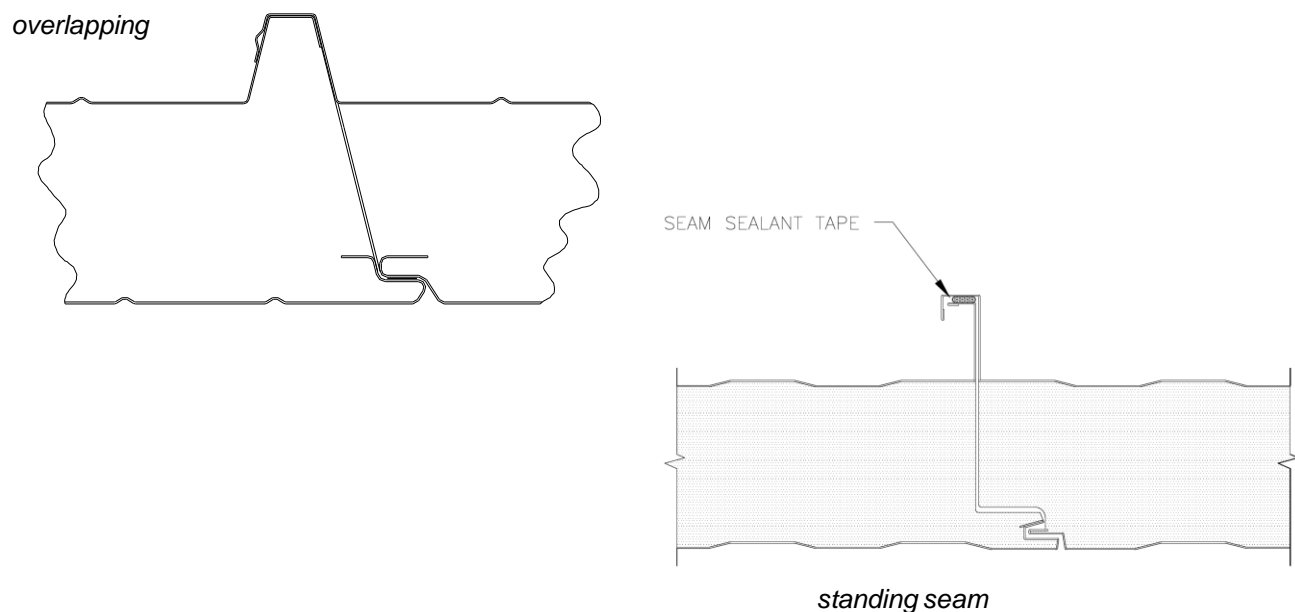

Most insulated metal wall panels may be oriented either with the length of the panel running vertically or horizontally as shown in Figures 4 and 5.

Figure 4. Horizontal orientation

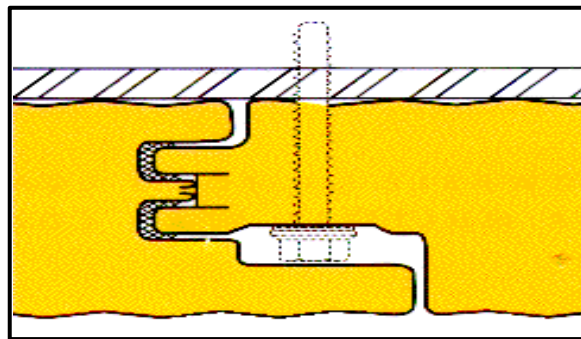
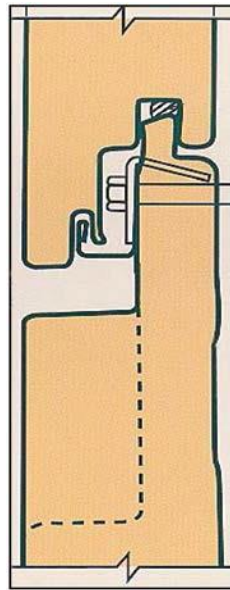

Figure 5. Vertical orientation

The panel core is usually a polyisocyanurate or polyurethane foam. The chemistry is usually proprietary to each manufacturer. The formulation contains the additives necessary to meet the fire performance of the given product geometry and to satisfy the needs of the manufacturing process. The density is typically between 2 and 3 pcf.

The panel weight will vary depending on thickness and gauge of the facings. A 2” panel with 26 gauge facings will weigh about 2.3 psf. The same panel with 22 gauge facings may weigh as much as 3.65 psf depending on the panel profile.

SECTION 5: DESIGN PARAMETERS

Thermal Effects

All IMPs must demonstrate the ability to withstand an applied temperature differential and extreme solar exposure conditions across the thickness of the panel (i.e. from the exterior to the interior facings). Panel temperatures on the outer facing can reach service temperatures of 180°F with dark colors or in extreme roof conditions. The surface temperature can be reduced by using lighter colors and paint systems containing cool infrared reflective pigments. The inner facing is usually limited to a lower in-service temperature. Depending on the manufacturer the maximum allowable liner temperature will range from 120°F to 160°F. It should be noted that panels manufactured in a pinch roll/contact adhesive process usually will not perform well in high temperatures. The minimum interior temperature for cold storage applications can be as low as -50°F. Applications with unheated liners such as beam wraps and screen walls may limit allowable panel lengths (of flat panels) due to thermal stress.

Thermal expansion is accommodated by a combination of thermal bow and thermal stress. Because IMPs are a composite sandwich with both the interior and exterior facings bonded to the core, there is no significant linear differential expansion between the interior and exterior facings. The insulated panels are positively fastened to the structure and the expansion of the panel is distributed among the individual spans as thermal bow rather than linear expansion. The overall panel does not significantly elongate or contract so there is no need to install an insulated metal roof panel with slotted clips. Thermal bow does not adversely affect the performance of the panels used in a properly designed system, since panel analysis calculations and best practices make allowance for it.

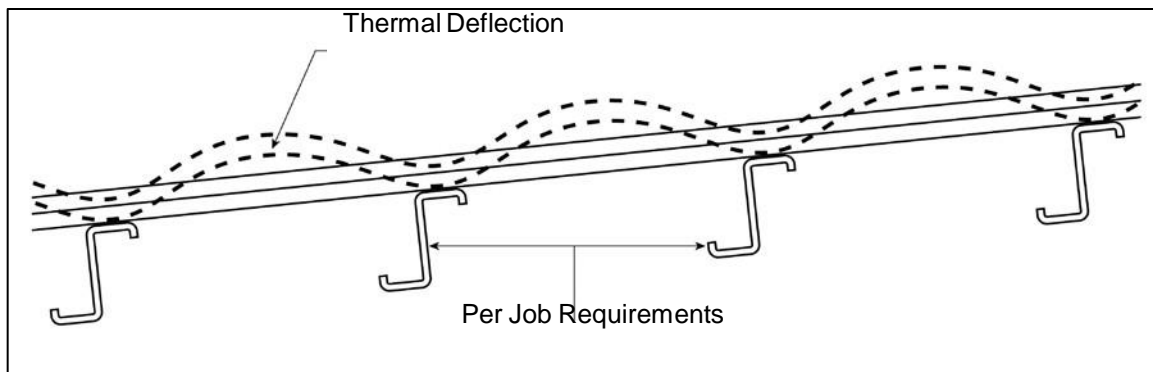

Metal Roof End Laps

As panel lengths are limited by practical concerns such as shipping and handling limitations, it will sometimes be necessary to provide an endlap joint for insulated metal roof panels. Typically, the inner facing (liner) and foam core will be cut away leaving a nominal exterior facing extension for a lap over the lower panel. The length of the extension and end lap is dependent on the roof slope and the panel profile.

The end lap joints are caulked and fastened according to the roof panel manufacturer's recommendations.

Metal Roof Slope

As with any metal roof, insulated metal roof panels must be installed to a minimum slope. The amount of slope required varies from manufacturer to manufacturer. Check the local code for minimum slope requirements; however a good rule of thumb is:

- Single length panels 1/4 inch in 12 inch slope
- Panels with lap joint 1/2 inch in 12 inch slope

These slopes should be considered as absolute minimums for warranty considerations. Consult panel manufacturer for project specific slope requirements.

Metal Roof Penetrations

Penetrations should be kept to a minimum. Where penetrations are required, small penetrations, such as VTRs, designed to interface with the IMPs exterior profile can be sealed with “boots” or stack flashings. For larger roof penetrations, a factory-welded curb, with additional structural support, is a common solution.

SECTION 6: INSTALLATION

While the installation of IMP is relatively simple when compared to multi-piece field assembled metal systems or built-up roof systems, there are certain very important requirements that must be met.

Support Gauge and Alignment

Because factory IMPs are strong and rigid the structure they attach to must be held to a closer tolerance than that required for some other systems. If the steel substructure has excessive variation from the theoretical plane, the IMP could be subjected to undo deflection stress at the connection points. This may result in aesthetic changes or diminished load capacity. It is recommended that the typical wall or roof panel attachments should be a minimum of 16 gauge steel. Fastening into wood is not recommended due to the cyclic fastener rocking caused by the panel's reaction to temperature differences of its skins as the sun heats the exterior facing.

The alignment of the supports is important especially with the most commonly used back seal or inner facing-side seal systems where the support alignment establishes the final alignment of the wall. In addition, improperly aligned supports can induce stress in the panels and cause exterior facing distortions. Fastener pull out values should be reviewed for each project. The minimum suggested bearing width at purlins is 2½". It is necessary to specify steel tolerances and deflections similar to those required for insulated architectural walls. This requirement for steel alignment and deflection limits must be cross-referenced in the structural steel specification to ensure a quality installation.

For proper panel installation, the maximum deviation of a girt for industrial applications typically should not be more than 3/8" in any 20-foot length in any direction. The support alignment should not deviate more than ± 3/4" from the theoretical girt plane at any point on the wall (thicker panels may require tighter alignment tolerances). For architectural wall or roof applications, the support alignment should not deviate more than ± 1/4" in any 20-foot length in any direction. The total alignment envelope should be ± 1/2" over the entire panel surface with the exception of transition areas such as building corners and soffit areas where the alignment must be within ± 1/8" of the theoretical girt plane to accommodate formed transition or corner panels.

If there is variation in the steel alignment from the theoretical plane, it should all be in an outward direction. If one purlin is on the plus side and the adjacent purlin is on the minus side, this can induce unacceptable stresses in the insulated panels.

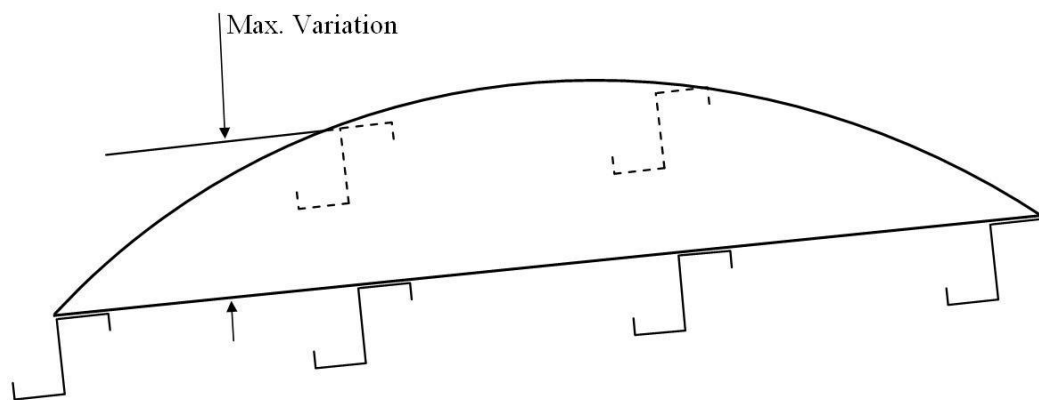
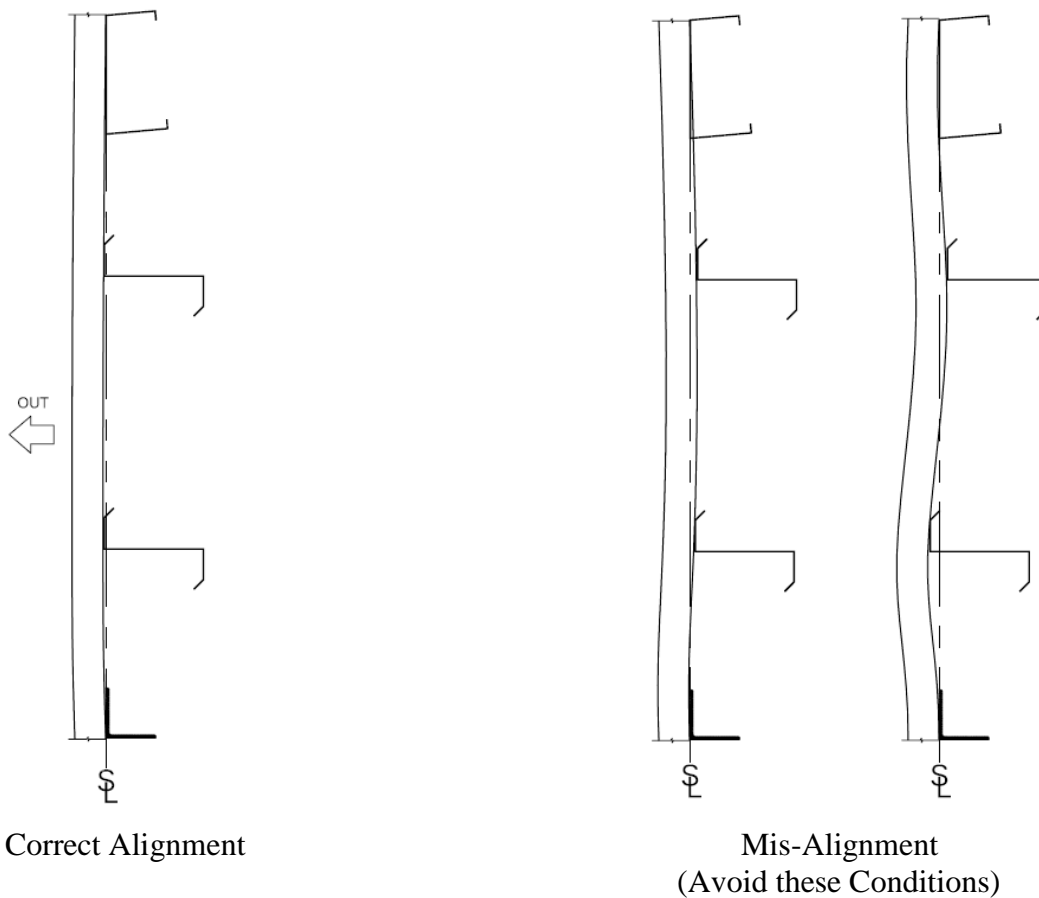

Example: An insulated roof panel spanning 5 feet with an allowable deflection of $L/180$ will deflect a maximum of $1/3''$. If the purlin supporting the panel is designed with the deflection limit of $L/240$ and spans 25 feet, the allowable deflection for the purlin is $1\frac{1}{4}''$. This differential can cause excessive deflection and stress in the insulated panels and panel connections.

All fundamentals of the system, including fastening details, trim details, and panel joints must be design coordinated to maximize panel performance.

The installer of the insulated metal wall and roof panels must check the supporting structure before starting installation. Any variations in excess of those noted above must be corrected prior to starting work or reported to the architect/engineer as soon as possible.

Panel Layout

Because of the rigidity of the insulated metal wall and roof panels maintaining proper layout and module of the panels is critical for proper installation. Layout and module control is especially important when the length of the roof slope requires an end lap condition or the wall panel requires a stack joint.

Panel Trim

Trim materials differ with the application and aesthetics desired. For industrial projects press broken trim is quite functional. A 26 gauge minimum thickness can be used when the exterior facing of the panel is also 26 gauge. To achieve a higher-level architectural presentation with crisper sight lines, extruded trim or a heavier gauge of press formed trim should be specified. Both types of details are presented in Section 7: Detail Illustrations, which begin on page 19.

Panel Clips and Fasteners

To achieve published load values, fasteners and clips as recommended by the manufacturer must be used. Fasteners are as equally important as clips and should be installed according to the manufacturer's instructions as verified by the structural calculations. In addition, they should be installed normal to the structure and the panels. They are not to be overdriven nor under driven because either condition can result in failure to resist pullout or failure and leakage of fasteners with sealing washers.

Panel Caulking and Sealants

To achieve the noted air and water infiltration performance levels a proper seal system is imperative. The most common technique is the inner facing (liner) side seal network. For non-refrigerated buildings, this involves field applying non-skinning butyl sealant on the structural steel at panel ends and connecting them to either shop or field applied sealant located in the panel side joint. The result is that each panel has a complete perimeter of butyl sealant on the inner facing (liner) or warm side, which in turn creates an excellent vapor barrier. At transition areas such as corners or wall to soffit edges, proper liner trim is needed to maintain the liner seal continuity.

A major advantage of the liner seal technique is that the critical seals are located away from the facing of the panel, and will not cause staining or dirt attraction as occurs with other types of wall panel systems that are faced sealed. It is important that vertical panel systems with a double tongue and groove side joint allow water to weep at the panel base.

Refrigerated buildings generally have special conditions to consider before locating seals. This is because water vapor being driven into a very cold space can cause buildup of ice and may lead to permanent damage of the joints. Therefore, it is important to consult the manufacturer before deciding which skin to seal.

For weather tightness, most insulated metal roof panels require a concealed bead of sealant on the exterior of the panel side joint. Continuity of panel caulking is critical. All joints and overlaps must be completely caulked to prevent water and air infiltration. Caulking of end lap panel joints is especially critical as the lap occurs in the "low" flutes of the panels.

Key performance items for inclusion in a guide specification are shown in Addendum 2.

Summary

IMPs offer benefits for the entire building team. To reiterate, the owner achieves a thermally efficient, high performance product that has superior life cycle costs and is provided with performance certifications that pre-qualify the complete wall or roof assembly for building code and insurance compliance. The designer works with a product that offers many design and performance options. The erector works with a product that is easy and quick to install in almost any weather condition, in response to the common tight building schedules of today's market. When you consider insulated metal panel products, use the information presented herein as a start to properly promote, specify and detail a project. Additional information is available from the specific manufacturers. Contact the MCA for a list of member manufacturers.

SECTION 7: DETAILED ILLUSTRATIONS

The side joints and fastening methods shown on the following details are to be construed as generic and schematic in nature. All references to “extrusions” pertain to aluminum extrusions. The different manufacturers have modules, profiles and side joints that are specific to them. For example, side joints can be standing seam, interlocking, or overlapping.

Vertical Panel Details

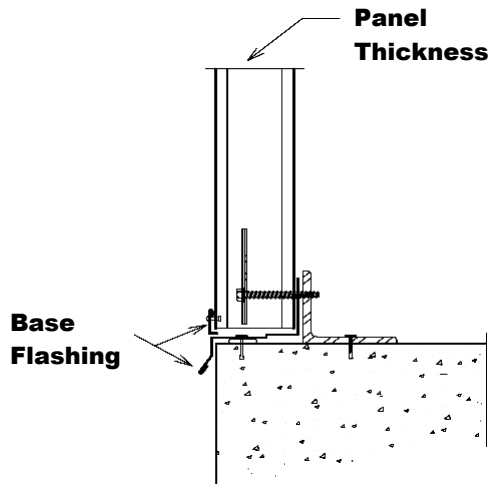

Base-Flashing

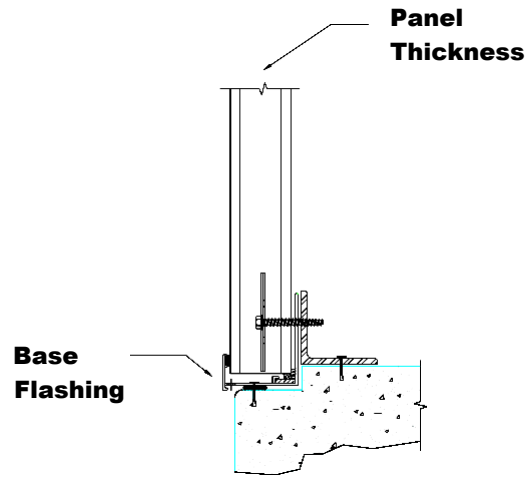

Base-Extrusion

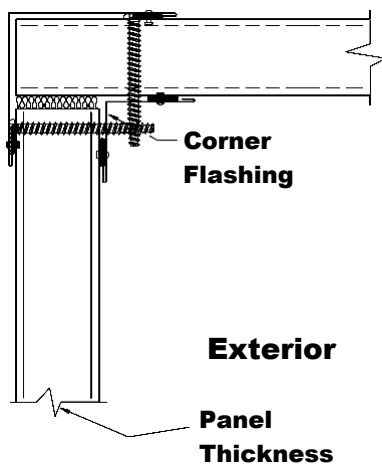

90° Inside Corner-Flashing

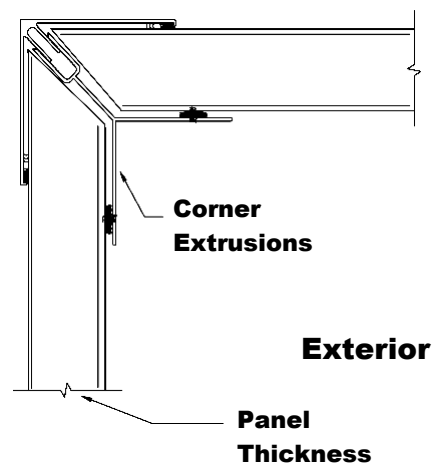

90° Inside Corner-Extrusion

Vertical Panel Details

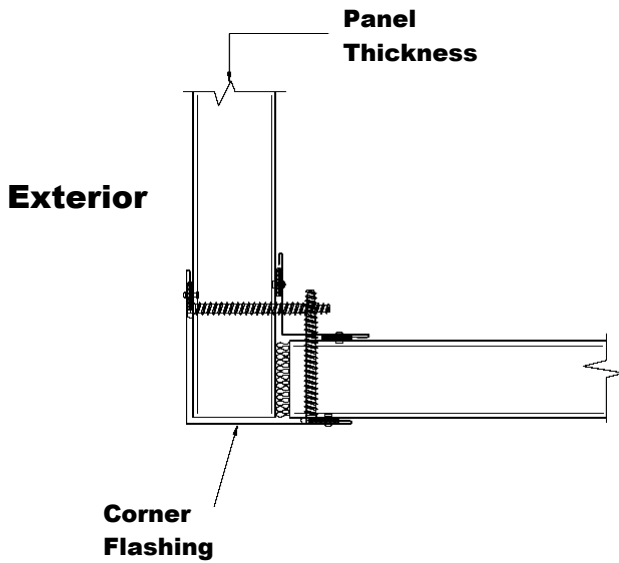

Corner-Flashing

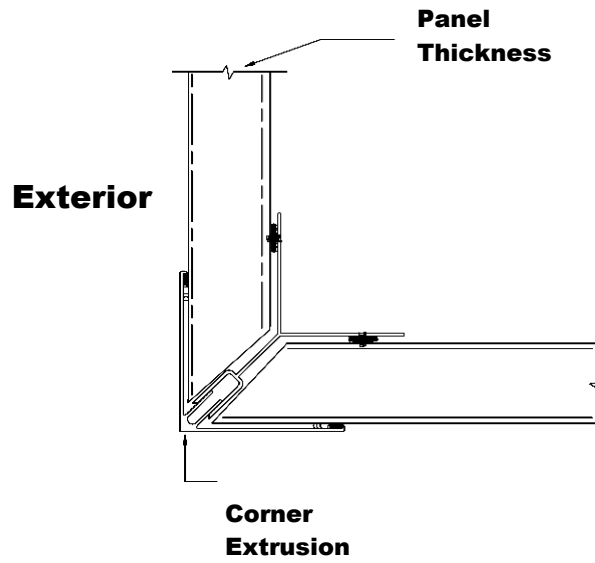

Corner-Extrusion

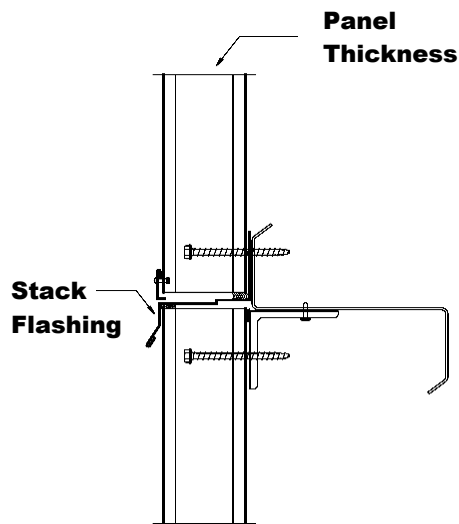

Stack-Flashing

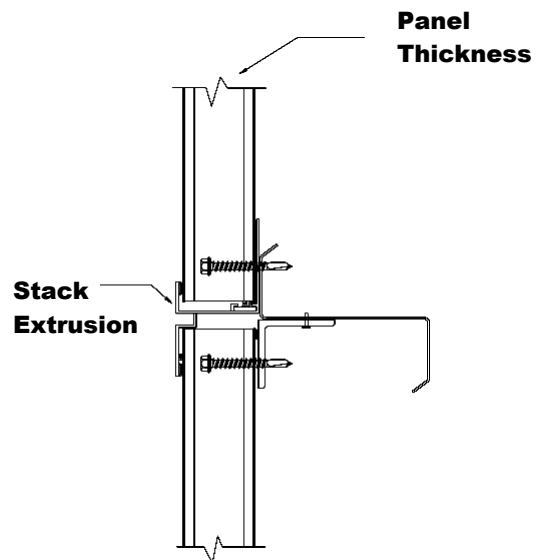

Stack-Extrusion

Vertical Panel Details

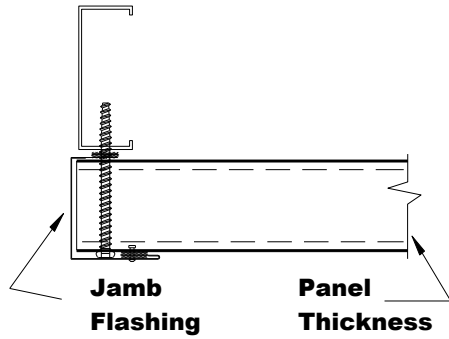

Jamb-Flashing

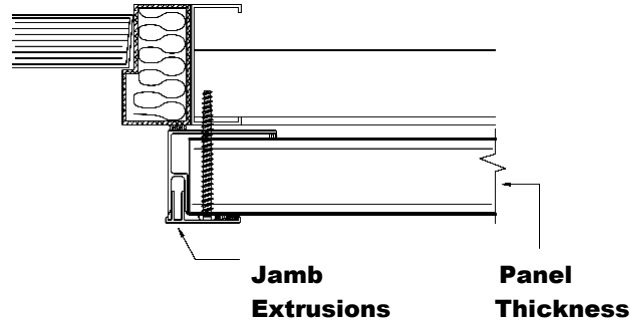

Stack-Extrusion

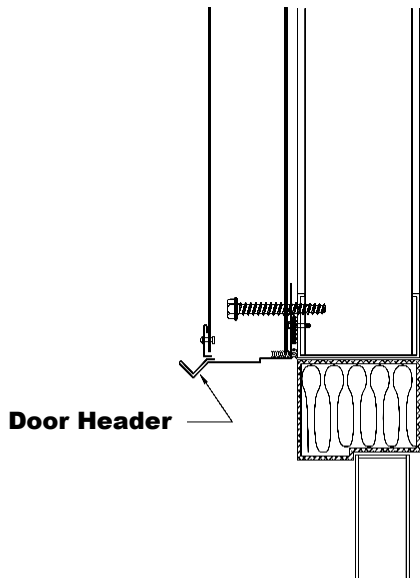

Header Flashing

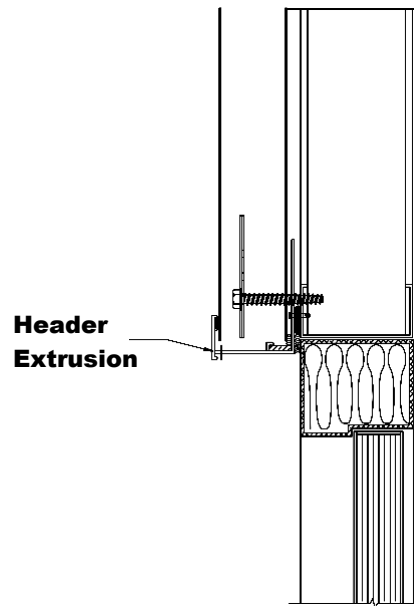

Header Extrusion

Vertical Panel Details

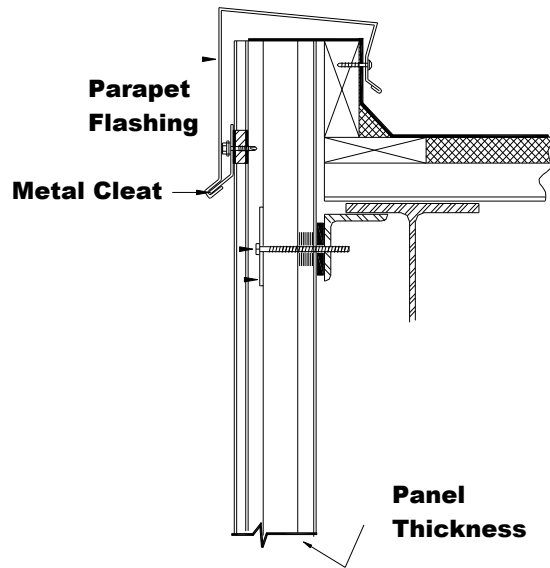

Parapet-Flashing

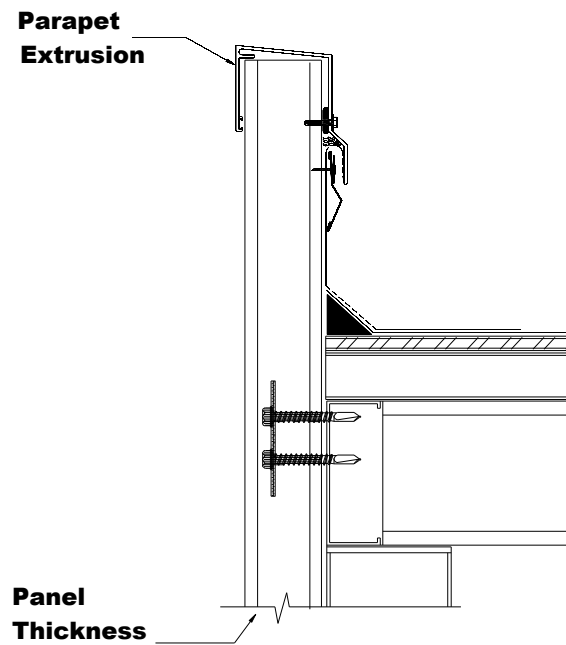

Parapet-Extrusion

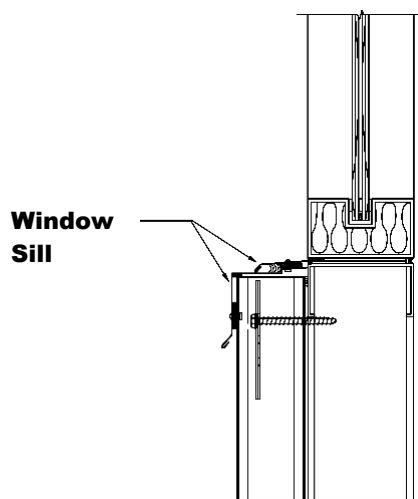

Window Sill

Horizontal Panel Details

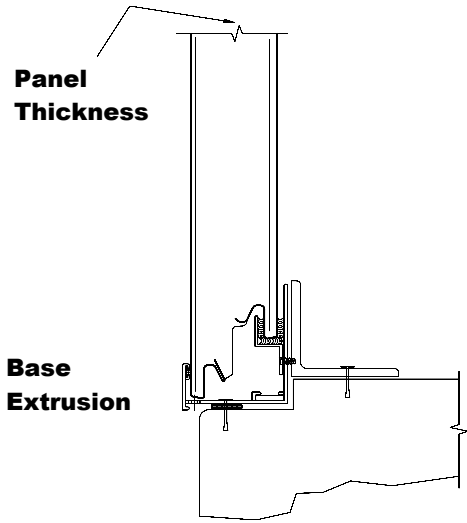

Horizontal Base Extrusion

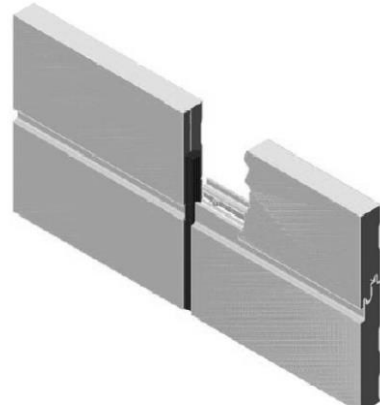

Four Corner Joint Detail

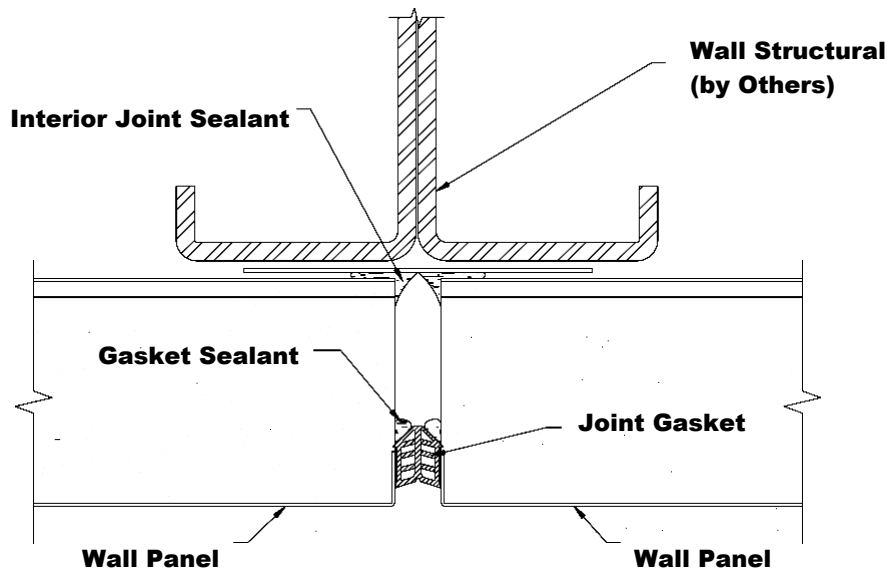

Vertical Joint Detail

Roof Panel Details

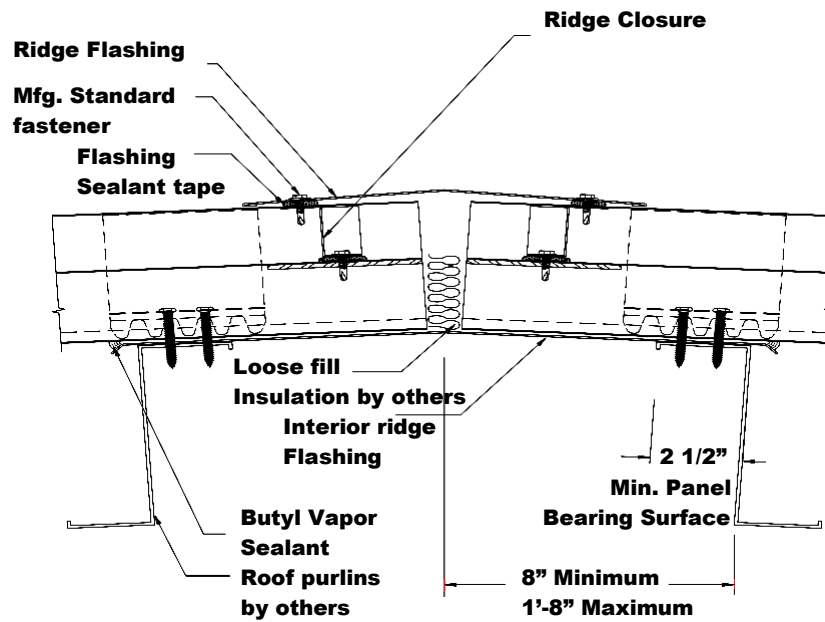

Ridge

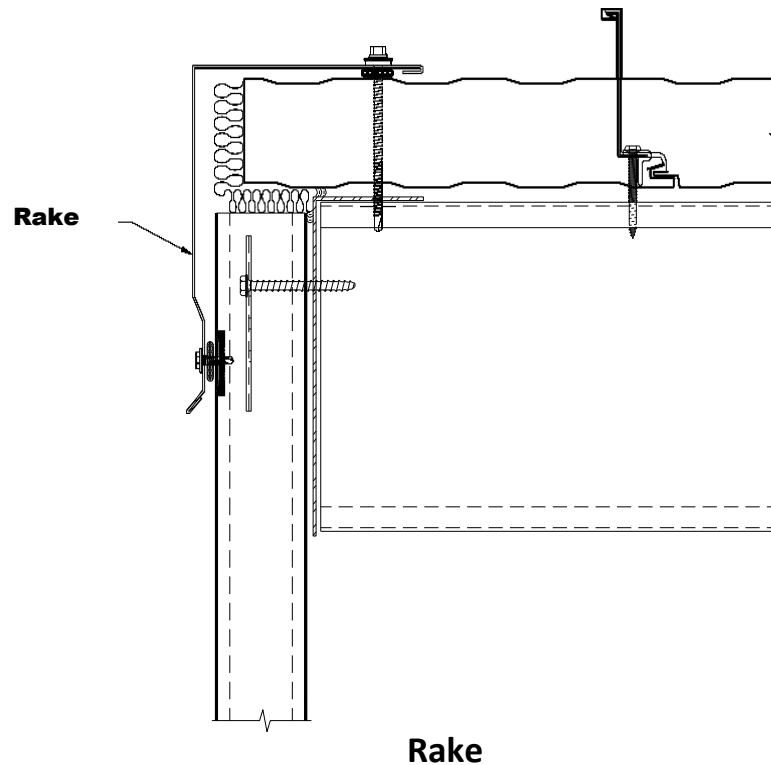

Roof Panel Details

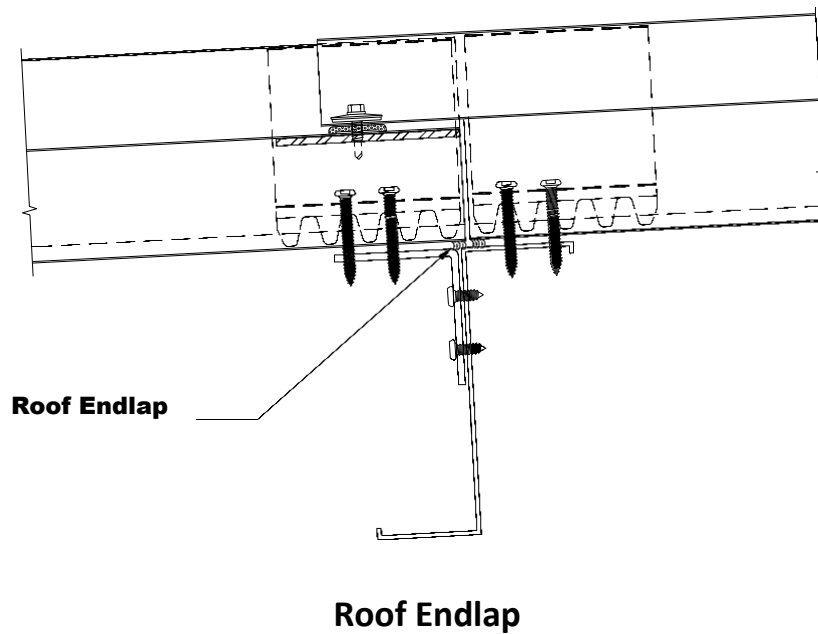
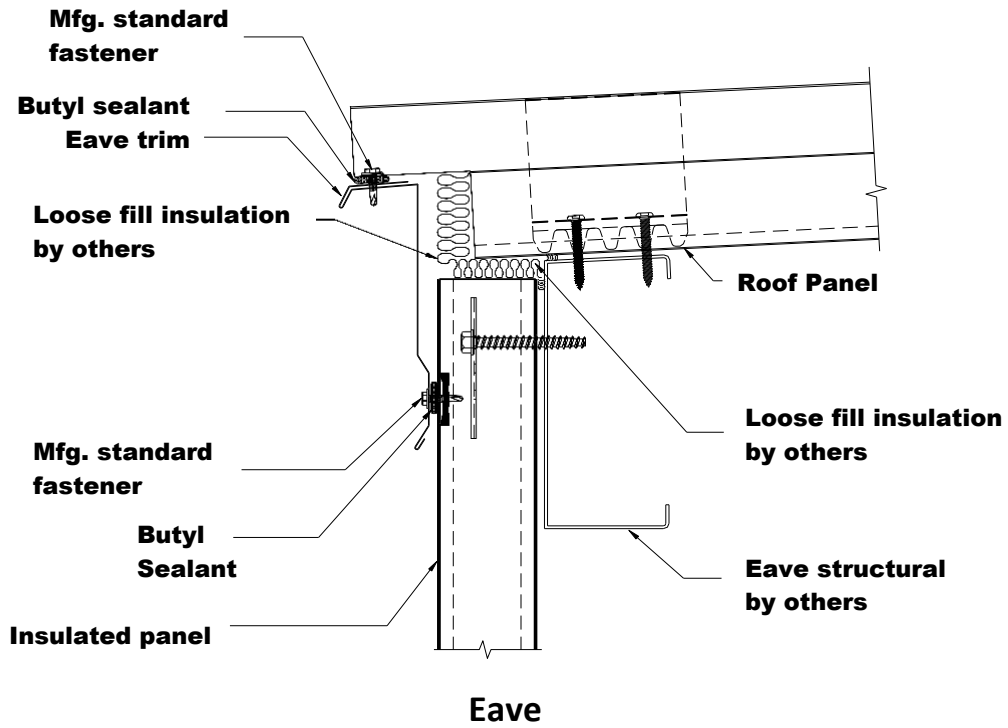

ADDENDUM 1: FEATURES, FUNCTIONS, BENEFITS

Feature	Function	Benefit
Single manufactured unit	<ul style="list-style-type: none"> • Quick erection • Minimizes Erector impact on product quality 	<ul style="list-style-type: none"> • Labor cost savings • Shorter project schedule • Better in-place quality
Insulated core	<ul style="list-style-type: none"> • Provides good insulation and efficiency • Structural core 	<ul style="list-style-type: none"> • Energy cost savings • Long span high load performance
Metal Skins	<ul style="list-style-type: none"> • Provides moisture resistance • Offer design flexibility via color/ coating options 	<ul style="list-style-type: none"> • Weather integrity • Vapor barrier • Design options and durability • Warranted finish
Light Weight	<ul style="list-style-type: none"> • Easy to handle • Lower dead loads • Lighter foundations 	<ul style="list-style-type: none"> • Minimize labor • Material savings
Concealed attachment	<ul style="list-style-type: none"> • Fasteners protected from the elements 	<ul style="list-style-type: none"> • Increased longevity • No rust stains
Specific joinery	<ul style="list-style-type: none"> • Allows use of the product in horizontal and/or vertical positions 	<ul style="list-style-type: none"> • Improved weather integrity • Design flexibility/joint size and orientation
Thermally broken side joinery	<ul style="list-style-type: none"> • Avoids thermal through conductivity • Avoids cold spots 	<ul style="list-style-type: none"> • Lower energy costs

ADDENDUM 2: INSULATED METAL PANEL GUIDE SPECIFICATION BULLETS

- In-Place insulation performance:
R value = _____ per ASTM C 1363
- Product Structural Performance under Positive and Negative wind loads when tested in accordance with ASTM E330 or ASTM E72:
Wind Loads in accordance with ASCE 7 and code requirements:
General Area Loads ___ psf Corner Area Loads ___ psf
- Maximum Air Infiltration when tested in accordance with ASTM E283:
.03 cfm/ft² at 1.56 psf
.04 cfm/ft² (Reference Footnote 1)
- Water Infiltration when tested in accordance with ASTM E331:
Tested at a minimum pressure of 6.24 psf
- Fire Performance: Certified and compliant with the requirements of the International Building Code or the code enforced within the local jurisdiction.
Evidence of testing required.
- Support System Alignment/Architectural
0.25 inch per 20 feet in any direction, ± 0.5 inches max, 0.125 inch in corners
OR
Support System Alignment/Industrial
0.375 inch per 20 feet in any direction, ± 0.75 inch max
- Trim: ___ gauge min. press formed trim required
OR
Trim: Extruded Trim required Service Temperatures
180 °F maximum panel Temp
___ °F maximum facing Temp
___ °F minimum facing Temp
- Core Properties
Density: ASTM D 1622
Tensile Strength: ASTM D 1623
Compressive Strength: ASTM D 1621
Shear Strength: ASTM E 72
- Finishes: Type/PVDF
Warranty
Performance levels (see supplier info)

¹Comply with the version of ASHRAE 90.1 Standard that is effective in local jurisdiction. For example, ASHRAE 90.1 - 2010 standard will require assemblies of materials and components (sealants, tapes, etc.) that have an average air leakage not to exceed 0.04 cfm/ft² under a pressure differential of 0.3" w.g. (1.57psf) (0.2 L/s.m² @ 75 Pa) when tested in accordance with ASTM E 2357 ASTM E 1677, ASTM E 1680 or ASTM E283; The following assemblies meet the requirements of 5.4.3.1.3 b.

(http://www.energysavers.gov/your_home/insulation_airsealing/index.cfm/mytopic=11600)

At the time of printing this manual, these numbers are per ASHRAE and anticipated ASHRAE 20b, check with your engineer for current Maximum Air Infiltrations.

Founded in 1983, the Metal Construction Association brings together the diverse metal construction industry for the purpose of expanding the use of all metals used in construction. MCA promotes the benefits of metal in construction through:

- Technical guidance
- Product certification
- Educational and awareness programs
- Advocating for the interests of our industry
- Recognition of industry-achievement awards
- Monitoring of industry issues, such as codes and standards
- Research to develop improved metal construction products
- Promotional and marketing support for the metal construction industry
- Publications to promote use of metal wall and roof products in construction

For more information, please visit the MCA Web site at www.metalconstruction.org

Copyright © 2017 Metal Construction Association. All rights reserved.

No part of this publication may be reproduced in any form or by any means, including photocopying, or utilized by any information storage or retrieval system without permission of the copyright owner.

This document is for general information only. The document is designed to delineate areas requiring consideration. Information contained in the document should not be used without first securing competent advice with respect to its suitability for any given application. MCA does not assume responsibility and disclaims any representation or warranty, express or implied, that such information is suitable for any general or particular use. Anyone making use of the document assumes all liability resulting from such use.

The existence of the document does not in any respect preclude a member or nonmember of MCA from manufacturing, selling, or specifying products not conforming to the document, nor does the existence of an MCA document preclude its voluntary use by persons other than MCA members. The document does not purport to address all safety problems associated with its use or all applicable regulatory requirements. It is the responsibility of the user of the guideline to establish appropriate safety and health practices and to determine the applicability of regulatory limitations before use of the document.

The Metal Construction Association reserves the right to change, revise, add to, or delete any data contained in the document without prior notice.

It is the responsibility of the end user to verify the applicability of this information with the local building and fire officials.