



Metal Roof Installation Manual

Chapter 20: Re-roofing

METAL CONSTRUCTION ASSOCIATION

8735 W. Higgins Road, Suite 300, Chicago, IL 60631

847.375.4718 | mca@metalconstruction.org | www.metalconstruction.org

BUILD LEGACIES
 METAL

Chapter 20: Re-roofing

Chapter Contents

20.	Introduction	20-1
20.1	Pre-installation Considerations	20-1
20.1.1	Existing Building Evaluation	20-1
20.1.2	Roof Layout.....	20-2
20.2	Existing Roof Preparation	20-4
20.3	Installation Differences	20-4
20.3.1	Metal Overlays	20-4
20.3.2	Retrofit.....	20-5

20. INTRODUCTION

Millions of square feet of existing roofs installed 20-40 years ago are currently in need of replacement. The same characteristics and qualities which make a metal roof system an excellent choice for a new roof also make it an excellent choice when a roof replacement is necessary. Long life, low maintenance, lightweight, and energy considerations make the metal roof an "upgrade" for many older structures.

In addition to long life and low maintenance, there are other reasons to select a metal roof. Aesthetics, energy efficiency, and an entirely different roof line are reasons easily achieved using a metal roof.

This installation manual primarily addresses the installation of a *new* metal roof system on structures. This chapter, however; addresses factors an installer needs to consider when installing a metal roof over an *existing* roof system.

In re-roofing applications there are essentially two ways to re-cover an existing roof. These two methods are shown in Figure 20-1. The first uses a metal overlay, which keeps the existing roof slope, and merely re-covers the existing roof membrane. The second, a retrofit, is a complete, fully-engineered metal system designed for installation over existing flat or sloped roofs and walls. It takes the existing roof surface, modifies the slope, and then re-covers it in metal. Both types require certain verification procedures prior to any re-roofing. These verifications and some of the necessary design considerations will be addressed in this section, as they will affect the work the installer must perform.

20.1 Pre-installation Considerations

Before installing a metal roof over any pre-existing roof, there are items which must be

evaluated, design limits which must be checked, and activities which must be performed before actual re-roofing can begin.

The results of these considerations will determine the steps, methods, and materials which the installer must use during the re-roofing installation.



Figure 20-1
Two Re-Covering Methods
Metal Overlay (Left) and Retrofit (Right)

20.1.1 Existing Building Evaluation

The findings of the following items as they relate to the structure to be re-roofed have the most direct impact on the installation process:

1. The integrity of the existing roof deck, including rust, rot, holes, and also its capability to support and transfer concentrated loads and additional shear loads to the underlying structural.
2. The capability of the existing building to accept the additional 3-5 PSF (per-square-foot) dead load for the new retrofit roof system.
3. The capability of the existing roof members to support concentrated loads from the retrofit framing system, weld integrity of the deck and structural members, and adequate joist bridging.
4. The capability of the existing roof structure to resist new roof, wind, and snow loads due to any change in the slope of the new roof.

5. The feasibility of continued operations within the building during the installation of the new roof system.
6. The need for an asbestos abatement study.
7. The level of water infiltration via a study of the existing roof system to determine the level of deterioration and moisture content.
8. Requirements and modifications to existing HVAC systems to accommodate the new retrofit roof system.
9. The integrity of the insulation in the existing roof system.
10. The structural integrity of the existing load bearing walls.
11. Requirements for venting the retrofit roof system.
12. The addition of any "collateral loads" (i.e. sprinkler systems, HVAC systems, ceiling tiles, etc.) that may not have been included in the design of the existing roof system.

If tear off and replacement is being considered, a new standing seam roof should not be provided as a replacement for a screwed down metal roof without a complete structural analysis of the existing purlins. Screwed down systems brace the purlins and standing seam systems do not. As a result, the purlins may need to have additional bracing added before the standing seam roof can be installed.

It is always a good idea to have the existing building checked by a structural engineer before a reroofing project is undertaken. In any re-roof or retrofit project it is recommended to verify in the most recent code whether the existing roof must first be removed.

20.1.2 Roof Layout

A few simple rules-of-thumb help minimize the costs of the retrofit roof system and reduce potential water infiltration issues. Most leaks occur at complicated flashing transitions, changes in roof slope, dead-end valleys, and mechanical/plumbing penetrations. Simplifying the roof-line eliminates potential problems and maximizes the performance of the metal roof. If the building consists of several roof elevations, a single roof-line can be achieved throughout the building using a retrofit system as shown in Figure 20-2.

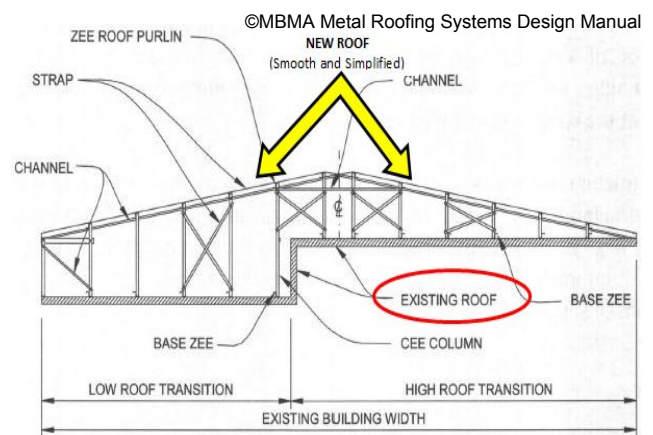

Figure 20-2
Simplified Roof-Line from Retrofit

Running the retrofit ridgeline perpendicular to the existing structural members, illustrated in Figure 20-3, also minimizes the framing costs.

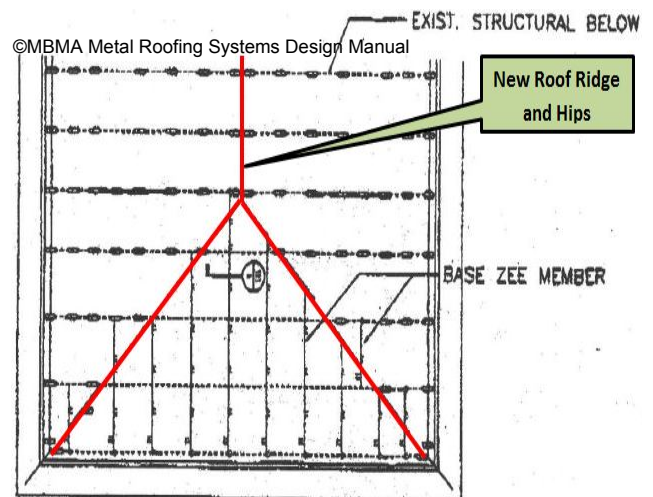

Figure 20-3
New Ridgeline with Retrofit

Installer Note

"What If the Existing Roofing is Wet?"

It is not unusual for the existing roofing materials to be wet in some areas. (Re-roofing would not normally be done if the old roof were not leaking.) By nature of their design and installation, all metal roofs create open areas which provide some ventilation. Metal systems involving a new slope-build-up substructure always create a plenum space. Regardless of height dimensions, this space is treated as an attic by all model codes, and it is vital that it be vented accordingly. Because the space is ventilated to exhaust moist air, the existing roof assembly will dry out rather quickly; just how quickly depends upon how much moisture is present, the specifics of the ventilation of the plenum space, and the climate at the project site. If wet roofing is encountered during the retrofit work, its location should be noted so that drying can be monitored, if necessary or desired, following construction. For more information on ventilation, see Section 8.1 *Ridge Vents – Types and Applications*, and Section 10.3.2 *Ventilation*.

There should be some concern regarding the type of fastener used when making attachments through wet roofing materials, as the wet material can greatly accelerate fastener corrosion. The fastener must be sufficiently corrosion-resistant to withstand the exposure to the moisture during the period in which the drying takes place, usually between two and ten weeks. If plated fasteners are used for routine fastening, it may be advisable to switch to stainless steel when encountering wet areas.

On some re-roofing installations, additional support members must be added to the base. Base structural members of the retrofit system are primarily used to:

1. Span between other structural members
2. Provide continuous attachment to the existing structure (Figure 20-4)

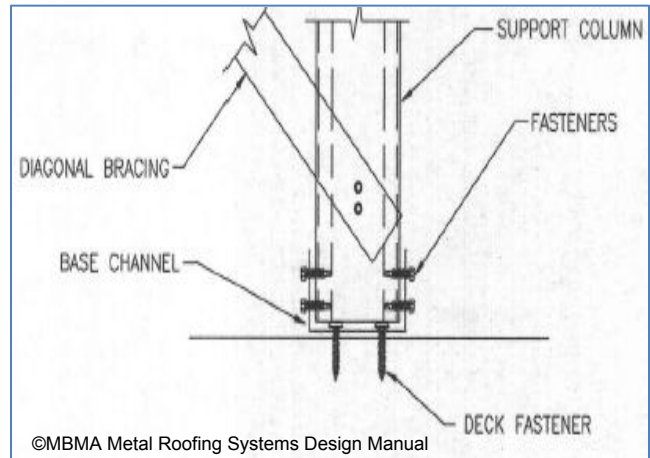

Figure 20-4
Re-Roofing Base Channel Support Structure
(Direct Attachment)

If the base structural member is running *parallel* to the existing deck flutes, reinforcement of the deck flutes may be necessary at existing structural locations to support the retrofit system. This can be seen and is illustrated in Figure 20-5.

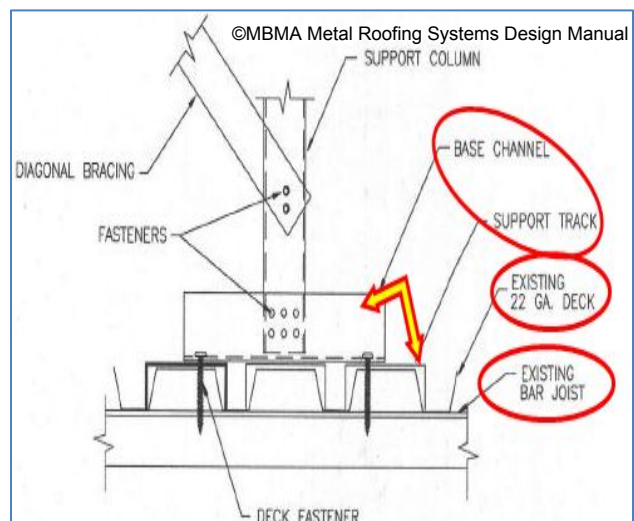

Figure 20-5
Reinforcement of Deck Flutes on Retrofit

20.2 Existing Roof Preparation

One of the benefits of choosing a metal roof to re-cover an existing roof is that the existing roof surface can normally remain in place. This saves many hours of labor, and landfill costs; however, there are still things an installer must do in order to prepare the roof for re-cover.

The following activities are applicable to any re-roofing application. Additional activities may be required based on job specifics.

- Inspect the roof for damage and make the necessary repairs.
- Secure any warped or loose roofing material.
- Make sure there are no nails or other objects protruding from the roof that might puncture new underlayment or damage the new roof panels.
- Remove all moss and other debris from the roof.
- Cut off any overhanging roofing so that it is flush with the roof deck; also remove all hip and ridge caps.

20.3 Installation Differences

While the results of a re-roofing are the same, there are installation differences based on which method is used. A retrofit normally requires more material and many different activities involving the sub-structure. A metal overlay often involves the installer in activities which are in close or direct contact with the existing roof surface.

20.3.1 Metal Overlays

A metal roof may be installed over existing roofs of shingles/shakes/slate, single ply, built-up and bituminous materials. Codes allow a metal roof to be applied over

another metal roof. Metal-over-metal installations are shown in Figure 20-6.

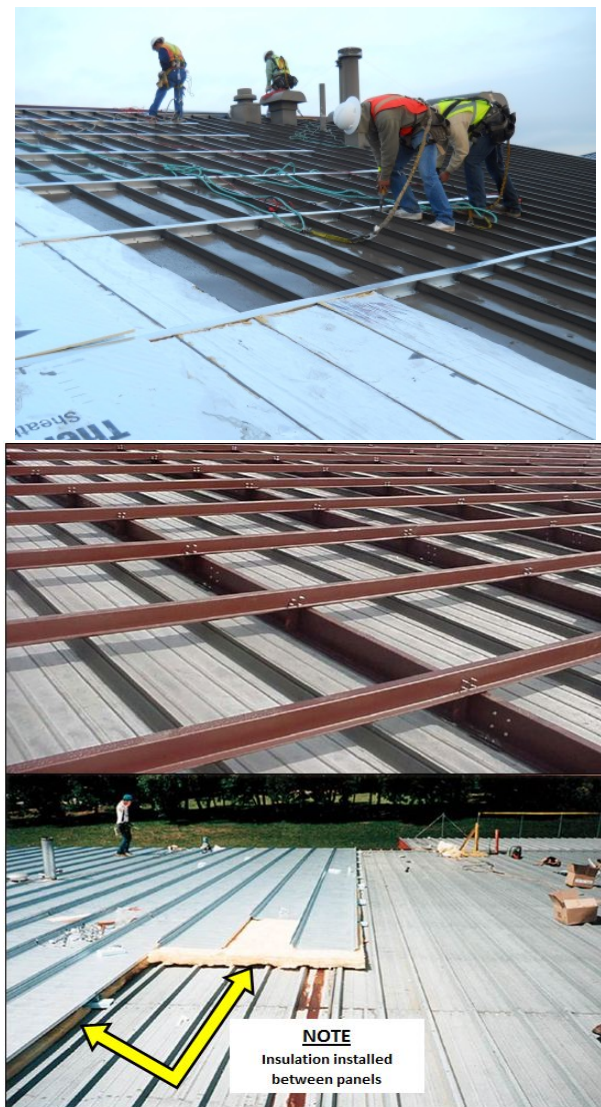

Figure 20-6
Metal-over-Metal Overlays Are Permitted

During a typical metal overlay installation, the installer performs the following steps as shown in Figures 20-7, 20-8, 20-9, and 20-10:



Figure 20-7

Step 1 - Metal overlays require smooth flat surfaces and preparation should begin with the activities mentioned in Section 20.2, Existing Roof Preparation.



Figure 20-8

Step 2 - Purlins of 2x2 or 2x4 lumber (left), pre-formed metal structural material (right), or pre-notched sub-purlins as seen in Fig. 20-10, are installed as shown.



Figure 20-9

Step 3 - Older roofs often have inadequate thermal protection and new energy codes require higher

alternative thermal protection. Therefore, insulation is often installed between the purlins.



Figure 20-10

Step 4 - New metal roof panels are then attached, secured at the purlins.



Figure 20-11
Retrofit Examples

20.3. 2 Retrofit

Retrofit re-covering of an existing roof not only restores the roof's performance, but is used to change and alter the roof's slope and other, more visual, characteristics. Figure 20-11 illustrates how a retrofit

installation changes an existing structure's roof and its appearance.

The new roof slope may require siding to be applied at endwall or sidewall locations, attached to the new retrofit framing system. In order to attach wall sheets to endwalls or sidewalls, the manufacturer may provide wall girts as shown in Figure 20-12. Girts are usually zees or hat sections that span horizontally from retrofit column-to-column at a designated spacing which meets the wind loads for the wall panel selected.

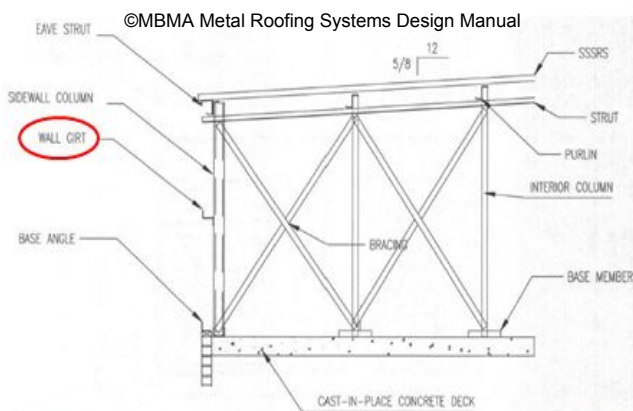

Figure 20-12
Retrofit Endwall Installation

A retrofit installation also provides the opportunity to change the roof appearance by easily adding overhangs as part of the new roof system. A typical endwall installation is illustrated in Figure 20-13.

To form an overhang at the eave, a support member must be added to cantilever beyond the wall line. A small truss frame system can be designed to attach directly to the existing wall. A typical installation example is illustrated in Figure 20-14.

Note

Before performing a retrofit, check and verify which building codes may apply.

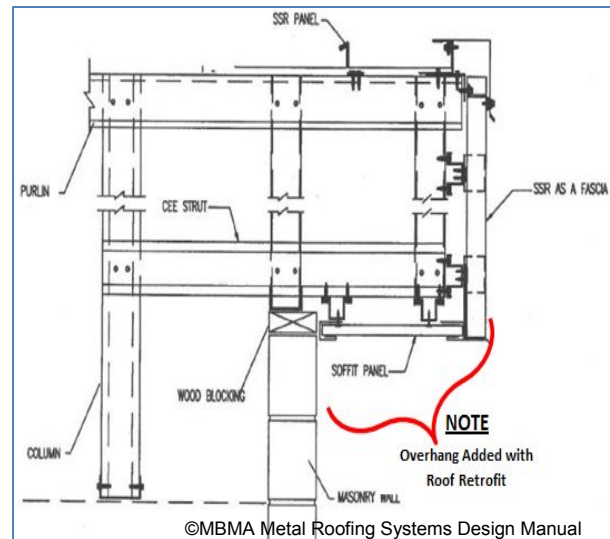

Figure 20-13
Endwall Overhang Added During Retrofit

