



# Metal Roof Installation Manual

## Chapter 8: Common Panel Accessories

METAL CONSTRUCTION ASSOCIATION

8735 W. Higgins Road, Suite 300, Chicago, IL 60631

847.375.4718 | [mca@metalconstruction.org](mailto:mca@metalconstruction.org) | [www.metalconstruction.org](http://www.metalconstruction.org)

BUILD LEGACIES  
 METAL

# Chapter 8: Common Panel Accessories

## Chapter Contents

<b>8. Introduction</b> .....	<b>8-1</b>
<b>8.1 Ridge Vents – Types and Applications</b> .....	<b>8-1</b>
8.1.1 Ridge Vents .....	8-1
8.1.2 Gable Vents .....	8-2
8.1.3 Soffit and Drip Edge Vents.....	8-2
8.1.4 Round Gravity Vents .....	8-3
8.1.5 Power Vents .....	8-3
<b>8.2 Roof Curbs – Types and Applications</b> .....	<b>8-3</b>
8.2.1 Pre-manufactured and Field Manufactured .....	8-4
<b>8.3 Roof Jacks</b> .....	<b>8-6</b>
<b>8.4 Skylights</b> .....	<b>8-7</b>
<b>8.5 Snow Guards – Types and Applications</b> .....	<b>8-8</b>
<b>8.6 Closures</b> .....	<b>8-11</b>
8.6.1 Eave .....	8-11
8.6.2 Ridge.....	8-12
8.6.3 Side / Gable .....	8-12
<b>8.7 Lightning Protection</b> .....	<b>8-13</b>
<b>8.8 Solar and Photovoltaic Systems</b> .....	<b>8-14</b>

## 8. INTRODUCTION

Common roof accessories include items like roof vents, curbs and jacks, access hatches, skylights, and snow guards. These items are not necessarily provided by the roofing system manufacturer. Some of these items may be ordered and shipped to the site from other manufacturers, while others may be made locally, even on-site. Depending on the accessory, and the specifics of the job, the installer may be directly involved in the installation of the accessory. In other cases, the accessories, or portions of them, are installed by other tradesmen, but still require the roofing installer to install the roof itself, flashing, and/or trim.

### Installer Note

Accessory items may, or may not, be included in a roof manufacturer's warranty. The manufacturer should be contacted concerning the installation of any accessory, its possible effect on the roof warranty, and further installation details of the accessory.

### 8.1 Roof Vents – Types and Applications

Proper ventilation is a critical factor affecting both a roof's efficiency and its longevity. In this section, common vent types and typical component applications will be discussed. Ventilation principles and concepts, along with roof ventilation system issues are covered in Chapter 10, *Roofing Design*, and Section 10.3.2, *Ventilation*.

### Installer Note

Ventilation components like those shown in this section will be part of the roof ventilation system and installation; however, additional ventilation components may be found during a roof installation and need to be addressed. These additional ventilation accessories may be part of other, separate, ventilation systems. These systems may include, but are not limited to, HVAC, welding, and paint systems.

#### 8.1.1 Ridge Vents

Heat rises, and unless directed elsewhere, will attempt to rise to the highest point within the structure, generally the roof ridge. Proper ventilation at this point in the roof system is important. The installer's skill when installing the correct components in this area is critical in order to avoid problems after the installation.

Most metal roof designs incorporate one of two commonly used ridge vent styles: a low profile ridge vent or a standard ridge vent. Keep in mind that although ridge vent styles are similar, each manufacturer often designs ridge-venting components specific to the panels being installed. These special components often have their own unique installation instructions and requirements.

Low-profile ridge vents are commonly used with architectural-style roofs. They are designed to blend in with the rest of the roof color, shape, and style. Low-profile vents are mostly used in "attic" installations and are normally considered part of the roof venting system. They are installed in conjunction with the rest of the ridge closures and components on a roof installation.

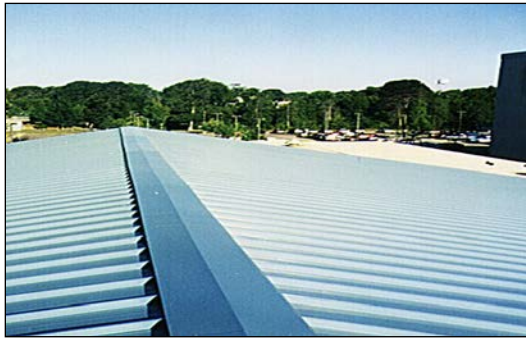

Figure 8-1  
A Low-Profile Ridge Vent Blends In with the Rest of the Roof Profile

Standard ridge vents, like the one seen in Figure 8-2, have throat sizes of 9 or 12 inches, and a standard length of 10 feet. They are common roof vents for industrial applications. Standard ridge vents are considered part of the "whole building" ventilation system and are used in conjunction with wall louvers, wall fans, and other components. They allow significant amounts of hot air to escape and are often equipped with operating dampers which allow adjustment for seasonal temperature changes.



Figure 8-2  
Standard Ridge Vent

Technically not ridge vents, but located near the roof ridge and similar in operation, are individual static vents. Static vents, as shown in Figure 8-3, are smaller than ridge vents, incorporate a low-profile style, and often are colored to match the roof panels.

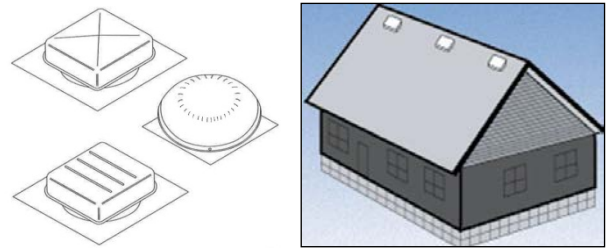

Figure 8-3  
Static Roof Vents and Typical Locations

**8.1.2 Gable Vents**

Gable vents, like the one shown in Figure 8-4, can function as an intake or an exhaust vent. When used without additional intake vents at the roof's low points, it will function as an intake or an exhaust vent, depending on the wind direction. The effectiveness of the gable-end roof vent is dependent on both the wind speed and direction. The vent

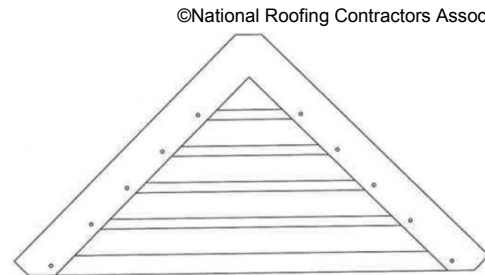

Figure 8-4  
Gable Roof Vent

is most effective with winds of sufficient speeds and from a direction perpendicular to the gable vent. The least effective vent operation results from light winds coming from a direction which is parallel to the vent itself. The size of the gable vent is dependent of the ventilation requirements for the roof installation.

**8.1.3 Soffit and Drip Edge Vents**

Soffit and drip edge vents are considered part of the roof vent system and function as intake vents rather than exhaust vents. They are designed to bring in cooler, outside air as the warmer exhaust air leaves the structure. Figure 8-5 illustrates several common vent designs. The most

common formats are continuous soffit panels with pre-formed vent openings; individually installed soffit vents, or pre-formed metal closure and trim pieces with pre-formed vent openings already molded into the piece. It is normal for each panel manufacturer to offer vent panels and trim pieces designed specifically to blend and match the exact roof panels being installed.

©National Roofing Contractors Association

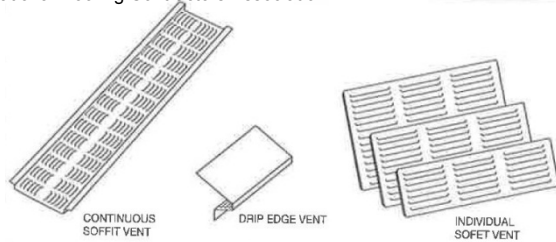

Figure 8-5  
Soffit and Drip Edge Vents

The number and type of intake vents required to properly vent the roof will vary depending on the roof design and the system requirements. It is important, however, to properly install all vents in order to prevent precipitation, animals, and insects from entering through the vent.

#### 8.1.4 Round Gravity Vents

Similar to the standard ridge vent, except round in shape, round gravity vents are unpowered, yet allow rising heat to freely escape. Made from 26 to 22 gauge steel, depending on the size, which ranges from 12" to 20" in diameter, round gravity vents can be used as either "whole building" or attic vents. Mounted on the roof slope, near the ridge, these unpowered vents also incorporate operating dampers for seasonal temperature changes.

©National Roofing Contractors Association



Figure 8-6  
Round Gravity Vent

#### 8.1.5 Power Vents

When the project specifications require precise air movement and control, a power vent is normally used. While fabricated from steel, aluminum, or a combination of the two materials, power vents are available in a wide variety of throat and motor sizes. Power vents are capable of adjusting exhaust air flow to meet any changes within the structure or the environment. Power vents are often similar in size and appearance to the previously described types of roof vents with the only difference being the power vent's internal motor and control circuitries.

### 8.2 Roof Curbs – Types and Applications

Roof curbs are raised members used to support roof penetrations such as skylights, mechanical equipment, and roof hatches. The curb raises the penetration connection above the level of the roof surface, reducing the possibility of leakage. Curbs also provide improved, and level (if necessary), surfaces for attachment of additional roof accessories.

Depending on the design requirements, a curb may be a 1 or 2-piece unit as shown in Figure 8-7, or a multi-piece unit with or without a separate, structural framework.

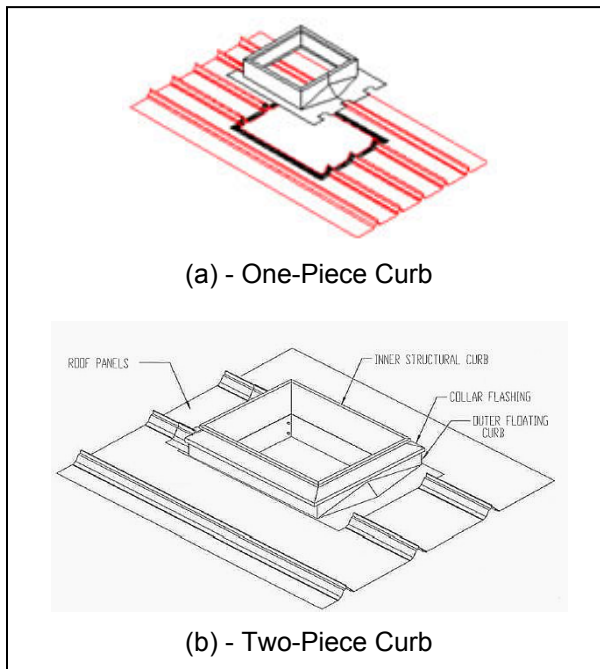

Figure 8-7  
One and Two-Piece Roof Curbs

Two piece curbs are generally used in retrofit applications where existing penetrations, such as chimneys or roof mounted equipment, cannot be removed and must be flashed around to provide a weathertight condition. Rooftop units that exceed the maximum weight requirements for single curbs will require a structural curb surrounded by a one or two-piece flashing curb attached to the roof system. Framing for this structural curb is not considered part of the roof system.

**8.2.1 Pre-manufactured and Field Manufactured**

Curbs present obstacles to the designed flow and drainage of the roof, but a properly designed curb as shown in Figure 8-8 will divert runoff and roof drainage around the curb. This is accomplished by having small crickets, diverters, or saddles, formed as an integral part of the curb structure. A large variety of roof curbs are available as standard accessories, but curbs can also be custom-made for a particular installation.

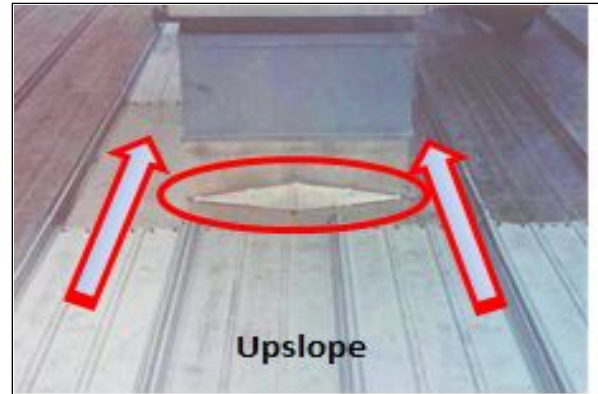

Figure 8-8  
A Properly Designed and Installed Curb  
Note Cricket and Drainage Clearances

Any curb installation will involve the installer. Responsibility for the curb installation may belong of other tradesmen, a joint effort between various trades, or the entire responsibility of the roofing team. Another point to remember is that curbs are an item that may be installed after the roof has been installed, or even in-service for a period of time. If the curb is not installed correctly, like the curbs pictured in Figure 8-9, sooner or later the roof will leak, and the customer may try to blame the initial roofing installer. Although not their fault, the roofing team *will* be expected to provide solutions to the problem. Figure 8-9 shows curbs that do not allow for good water drainage and are not properly sealed to the roof.



Figure 8-9  
Improper Curb Types

Curbs are installed in an "over-over," "over-under," or "under-under" configuration in relationship to the roof panels. This relationship is illustrated in Figure 8-10. The metal roof system manufacturer should

always be contacted concerning the use of roof curbs. Some manufacturers offer curbs exactly matching the roof panel profile, simplifying installation and flashing. The manufacturer may also provide recommended curb suppliers. Using a recommended supplier helps avoid warranty issues while ensuring system compatibility.

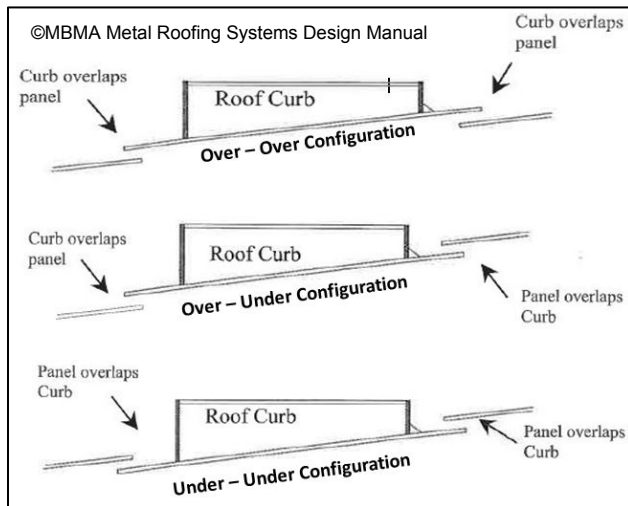

Figure 8-10  
The Curb – Panel Relationship

The previously mentioned types of roof curbs may also be divided into two groups based on their installed location. Some curbs are exact location curbs, while others are field-located curbs.

Exact location curbs are customized to fit at an exact location on the roof system. Because the curb must be located in an "exact" location, the roof installer may have to reconsider roof panel layouts in order to reduce the risk of leaks, and simplify trimming around the curb. The roof installer will need to coordinate the installation with the other trades involved to ensure that the penetrations have been properly located and sized to fit the curbs. This customized type of curb requires additional lead times, precise coordination of the trades, and increases the overall cost of the system.

Field-located curbs are manufactured to be installed without the need for locating the

exact curb location *prior to panel installation*. This type of curb is more common, especially since it has the benefits of shorter lead times and lower cost, but may not be suitable in every situation.



Figure 8-11  
Roof Curb Locations May Be  
Exact Location or Field-Located

There are several things an installer should consider in order to provide the best possible curb installation. Whenever possible, an installer should:

- Use curbs made from aluminum or stainless steel
- Use under/over curbs
- Use the following clearances:
  - Minimum 12" between panel end and diverter on the upslope
  - Minimum 6" between the curb sides and panel seams
- Use rib-to-rib curbs

Following these considerations, as shown in Figure 8-12, will provide an installation that will appear neat, perform as expected, and install in the easiest manner.

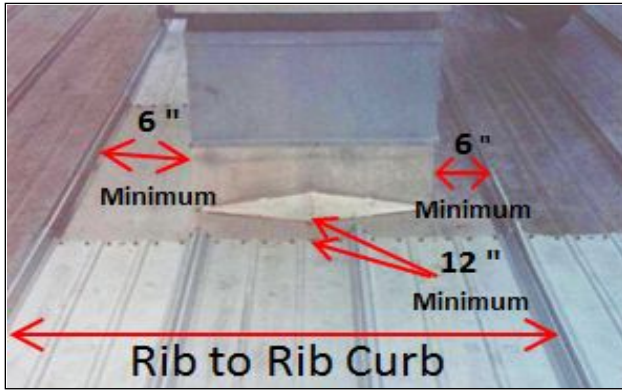

Figure 8-12  
Recommended Curb Clearances

8.3 Roof Jacks

Roof penetrations should be kept to an absolute minimum. Pipes and vents should pass through walls whenever possible, but when they must penetrate the roof panel, roof jacks are necessary. Roof jacks are used to flash around pipes and similar structural members that penetrate the roof surface. Just like the pipes themselves, roof jacks come in all sizes and shapes, but share common features.

Most roof jacks have a synthetic rubber "boot" which attaches to the roof panel with an aluminum flange using fasteners and sealant. The rubber boot is designed so the opening can be cut-to-size on-location and snugly fit over the penetrating item. Sealant is normally applied around this snug seal to provide additional protection from leaks.

Roof jacks are available from a variety of suppliers. Most metal roof manufacturers supply roof jacks designed to match the panels being installed.

A roof jack installation should be installed so it "floats," and is able to adjust to the thermal movement of the roof panel. Care should be used when attaching any roof jack fasteners so they do **not** engage the roof substrate, but merely secure the jack to the roof panel itself. This double pinning of

the roof panel to the deck surface often happens when either not enough deck material is removed around the penetration, or the flange of the roof jack is larger than the opening cut in the roof deck. An example of this type of improper installation is shown in Figure 8-13.

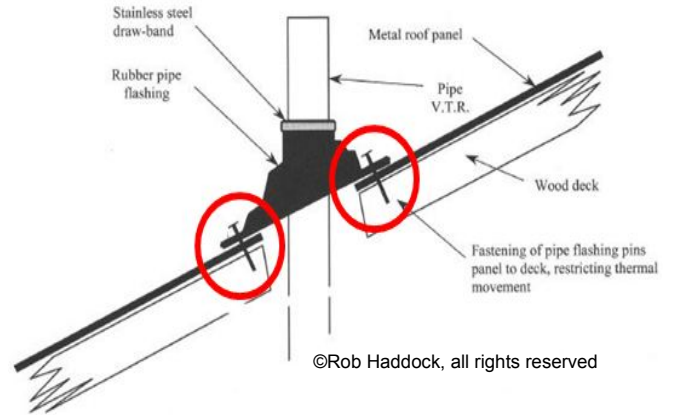

Figure 8-13  
Improper Roof Jack Installation  
Note Improper Double Pinning of Roof Panel

This double pinning is normally avoided by "over-cutting" the deck. Over-cutting is making the hole in the deck material larger than the base dimension of the roof jack. This eliminates the possibility of the fastener engaging the substrate while providing a clear area for any thermal movement of the roof panel. A properly installed roof jack installation using this method is shown in Figure 8-14.

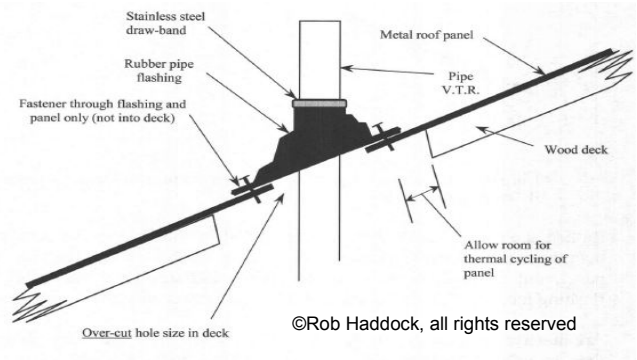

Figure 8-14  
A Properly Installed Roof Jack  
Note Over-Cutting Of Deck



The accessories that an installer chooses to use should always be of the highest quality. Metal roofs are designed and warranted to last for many years - sometimes up to 40 years or more. If a roof jack that is designed to last only 10 years is used on a long-term roof, it will fail and leak. This failure could be perceived as a roof failure and result in a loss of goodwill and possible litigation. This same reasoning should apply to any accessories an installer uses, including panel fasteners and sealants.

As noted in the discussion of roof curbs, roof jacks may also be installed long after the roof, and may have been installed by members of another trade.



Figure 8-15

Incorrect Roof Jack Installation by Other Tradesmen

Two incorrect roof jack installations are shown in Figure 8-15. These were installed by members of other trades who failed to properly consider the risk of roof leakage after installation. The photo on the left in Figure 8-15 shows a penetration through the panel seam. The photo on the right shows a conduit and gas line in one pipe jack. **Any** failure of a roof jack will probably result in a call to the roofing contractor who initially installed the roof.

**8.4 Skylights**

Skylights allow natural light to enter a building, providing both aesthetic appeal

and cost savings in lighting. These benefits have resulted in a growth in skylight use in both residential and non-residential applications. (See Figure 8-16) Skylights can be insulated, non-insulated, or glazed. Skylights can also be curb-mounted or mounted directly on the roof.



Figure 8-16  
Typical Skylight Application

Additionally, many panel manufacturers offer translucent roof panels like the one shown in Figure 8-17. These panels have identical profiles to a normal metal panel. During the roof installation, these translucent panels are installed in the place of a normal metal panel allowing light to enter the structure.

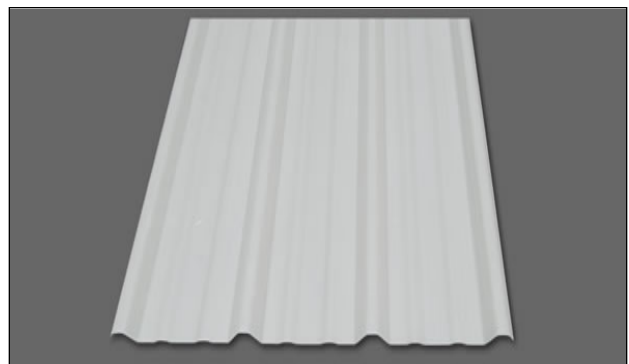

Figure 8-17  
Translucent Skylight Roof Panel

Skylight materials may have different coefficients of thermal expansion from metal trim and roof panels. They often move more than metal panels. It is advised that any fastener hole in the skylight used to fasten the skylight to a metal panel, be

oversized by 1/16" to allow for some differential movement.

### SAFETY NOTE

An installer must remember one rule around any type of skylight.

*Skylights ARE NOT a safe walking surface and should be protected from foot traffic.*



*Always ensure that the installation and use of all skylight panels comply with State, Federal, and OSHA regulations and laws, including, but not limited to, guarding all light transmitting panels with screens, fixed standard railings, or other acceptable safety controls that prevent fall-through.*

An installer's involvement with skylight installation may vary, but will certainly include trim and flashing around the penetration. It is important to remember that most installed curbs are designed to "float" in order to adjust to thermal changes within the roof system. The roof system manufacturer's instructions should be consulted to make sure the correct material and methods, specific to the panels being installed, are used.

## 8.5 Snow Guards – Types and Applications

Depending on the geographic location of the installation and climate considerations,

the issues created by snow and ice may need to be addressed.

Snow guards are used to minimize the potential for snow to slide off a roof, particularly in areas where it may pose a threat to pedestrian or vehicle traffic. Snow guards are also commonly used to prevent migration of snow into valley areas and other critical flashing conditions such as roof penetrations. The accumulated snow release can cause personal injury; property, structural and roof damage; and in extreme cases, even death.



Figure 8-18

The Sudden Release of Accumulated Roof Snow

Snow guards help to prevent the sudden release of accumulated snow so that it evacuates the roof in a more controlled fashion. Snow guards are of two types: individual "cleats" or continuous, horizontal bars or "fences". Snow guards of minimal height dimensions can be successful at restraining snow banks of many feet in depth. Examples of these types of snow guards are pictured in Figures 8-19, 8-20, and 8-22.

Whichever method is used to install snow guards, read and follow the installation instructions carefully. Improper installation could cause the snow guard to fail. Before installing any snow guard, the roof manufacturer should be contacted to make sure the addition of the snow guards will not change the panel installation requirements or void any warranty.



©Rob Haddock, all rights reserved

Figure 8-19  
Individually -Mounted Snow Guards Come In a Variety of Styles and Attachment Methods

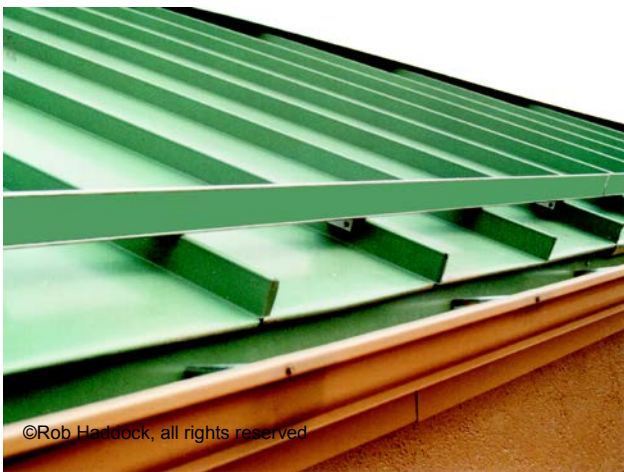

©Rob Haddock, all rights reserved

Figure 8-20  
A Snow Fence Type Clamp Attached to Standing Seams



Figure 8-21  
Electrical Ice Melt System Installed Along the Fascia Avoids Penetration of the Roof Surface

Snow guards are commonly made from either plastic or non-corrosive metals. If a

metal snow guard is used it should be compatible with the metal roof material. Aluminum is compatible with most metal roofs, except for copper. 300 series stainless steel alloys are compatible with all roof materials.

Snow guards are commercially available that attach to the roof with fasteners (mechanical bond) or adhesives (chemical bond). When a snow guard is adhered to a painted surface the ultimate strength of the bond may be determined by the strength of the paint's adhesion to the metal.

Other snow guards are mechanically installed, either by directly fastening through the roof panel, or by clamps secured to the raised seams of the panels.

Before installing any snow guard, the roof manufacturer should be contacted to make sure the addition of the snow guards will not change the panel installation requirements or void any warranty.

While snow guards that are installed using fasteners drilled through the panel into the substrate may provide a substantial mechanical bond, this method also punctures the panel, creating the possibility of leaks. When mechanically fastened snow guards are used the thermal movement of the metal roof system must be maintained. Do not over-tighten the fasteners, or damage to the snow guard and roof surface may occur.

For standing seam type roofs, snow guards that are installed using mechanical, non-penetrating methods are preferred. A wide variety of "seam-mounted" clamping devices are currently available. They generally follow the basic steps illustrated in Figure 8-22. It is critical to the proper and safe installation of this type of fastener that

the set screws are torqued to the proper value. The correct value is determined by factors such as gauge thickness of the panel, snow loading, clamp size, etc. The snow guard clamp manufacturer should be consulted for the correct torque value to be used for the installation.



Figure 8-22  
Example of Seam Mounted Fence System

Whichever method is used to install snow guards, read and follow the installation instructions carefully. Improper installation may cause the snow guard to fail. This may result in injury and damage, including to the roof system itself. A number of causes can lead to failure of snow guards adhered to a painted surface as seen in Figure 8-23. The roof damage shown in Figure 8-24 was caused by improper installation.



Figure 8-23  
Failure of adhesive applied snow retention devices due to inadequate quantity, or design of system, or improper adhesive type, or bonding failure



Figure 8-24  
Roof Damage from Improper Installation

Before installing any snow guard, the roof manufacturer should be contacted to seek his approval/recommendations and to make

sure the addition of the snow guards will not change the panel installation requirements or void any warranties. Some roof panel manufacturers also offer snow guard options making simple, single-sourcing possible.

The installation of snow guards will add snow weight to the roof system. An architect or engineer should verify that the structure was designed for the anticipated snow loads with the addition of such snow guards. With the use of seam clamp mounting devices on clip fastened metal roofing, review of the panel pinning or fix point detail should be taken to insure they can support the newly applied loads to this fastening connection or location.

Installation of additional ice-dam membrane material is recommended under, and upslope of, any ice-dam prone areas. Ice-melting devices may also be employed (Fig 8-21). In such cases, snow guards are used above the ice melt area to protect it from damage.

## 8.6 Closures

Closures, or closure strips, are used to close exposed profile openings formed between panels and trim. Normally panels are "finished" with flashings or trim pieces, but most panels also use closures. Closures are especially useful on the eaves, ridges, valleys, and hips to seal the exposed rib openings of pre-formed roof panels. Sealing these openings prevents the entry of moisture, insects, and debris. Closures may be made from metal or a resilient material, like foam or rubber.

Most closures are designed and made for specific panels and profiles, and are ordered directly from the roof system manufacturer. They are normally ordered at the same time the roof panels are ordered, and in an amount which will allow for extra closures. When installed, some closures

require the use of an appropriate sealant. Appropriate sealant and application details are found in the roof manufacturer's panel instructions.

### 8.6.1 Eave

Proper closure application during the eave installation is especially important due to the nature of the eave itself. The eave is located on the downslope end of the panel installation, and normally overhangs and interfaces with a gutter or some sort of drainage component. The eave installation is exposed to, and must handle significant amounts of water, dirt, and debris runoff during normal conditions, and is often the first area affected during extreme or unusual conditions. Openings in the eave area are also subject to windborne moisture, dirt, and insect entry.

Metal closures, sometimes called "Bird-Stops," are used when panels with larger openings, or profiles, are exposed. These closures are made to match the roof panel profile. In addition to visually enhancing the installation, they serve to prevent birds, larger insects, and debris from entering the opening. Additional steps must be taken to prevent moisture and air from entering the opening. Figure 8-25 illustrates two metal "Bird-Stop" closures made for roof panels which simulate a traditional clay tile roof.

Standing seam panels with larger ribs and panel profiles with intermediate rib configurations normally use specially shaped foam closures. (See Figure 8-26) These closures are available from the panel manufacturer and may require additional sealant when installed.

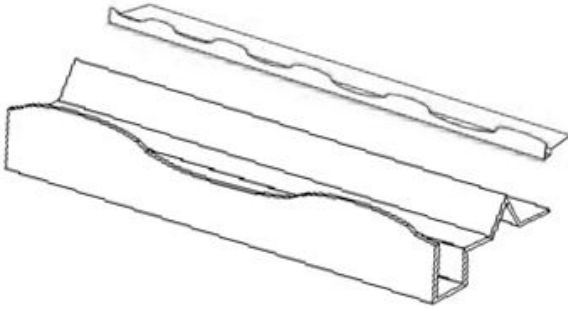

Figure 8-25  
Metal "Bird Stop" Closures

### 8.6.2 Ridge

Closures may also be necessary in order to properly finish the ridge installation. Although the ridge, being at the uppermost point of the roof, does not have runoff issues like the eave, it has its own set of concerns. The ridge installation has two roof areas coming together that must be properly protected from the environment. Since heat rises, the ridge area is also normally vented to allow removal of built-up heat from the roof structure. Often, especially in non-residential installations, the ridge vent is designed to provide additional structural ventilation. Refer to Section 8.1 for further information on roof vents.

Many methods are used to resolve the problem of protection from the environment while still providing exhaust ventilation from

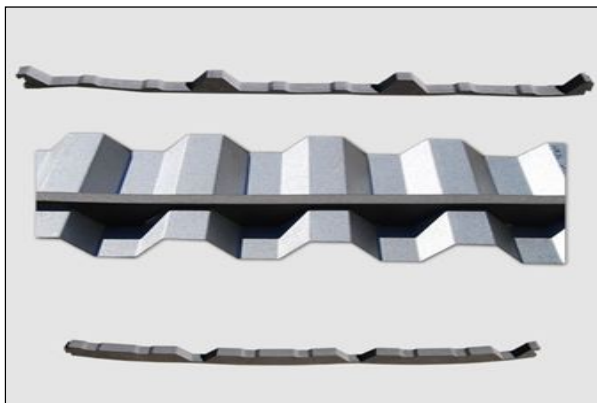

Figure 8-26  
Foam Closure Examples

within the structure. Some methods require the use of ridge closures which are similar

to eave closures. Other methods consider closing the exposed ridge openings as part of the ridge vent installation.

### 8.6.3 Side / Gable

Normal closure of side and gable openings is accomplished using specially formed flash and trim pieces. These pieces are designed specifically for the panel profile being used, and other job specific factors like fascia size and roof shape.

Proper closure of side and gable joints often requires the application of additional sealant. This additional sealant is typically applied at the panel seams, over fasteners, and around other openings per the manufacturer's installation instructions.

Depending on the directional orientation of the structure, the side/gable ends, and the prevailing wind directions, additional material and modified installation procedures may be necessary.

Horizontally-oriented panels, like Bermuda roofing, and metal panels simulating traditional clay tiles, wood shakes, or asphalt shingles, usually require special closures. These special closures are available from the roof system manufacturer.

## 8.7 Lightning Protection

Any general discussion of metal roofs soon turns to the topic of lightning and its possible attraction to the metal roof surface. There is no scientific evidence that lightning strikes more metal-roofed structures than those without metal roofs. However, lightning protection on any structure is a wise decision if the climate evidence supports such protection. A properly installed protection system, like the one shown in Figure 8-27, will offer protection, and most likely reduce the insurance rates on the structure.

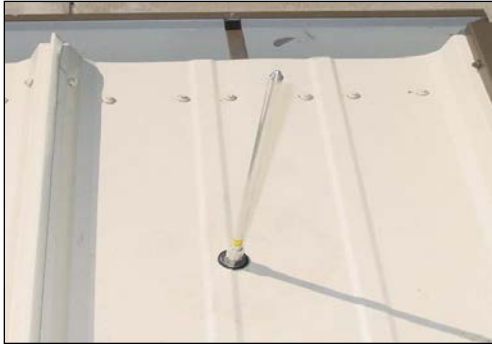

Figure 8-27  
Properly Installed Lightning Protection System

Installation of a lightning protection system may, or may not, be the responsibility of the roofing installer. Normally, the responsibility is shared with the electrical trades. The electrical trades are typically responsible for connecting the wiring to the electrical ground of the other systems, while the actual installation of the "rod" on the roof, and supplying related material may be the roofing contractor's responsibility. This is illustrated in both Figures 8-28 and 8-29. Notice that in Figure 8-29, the details and responsibility for different portions of the completed installation are clearly stated.

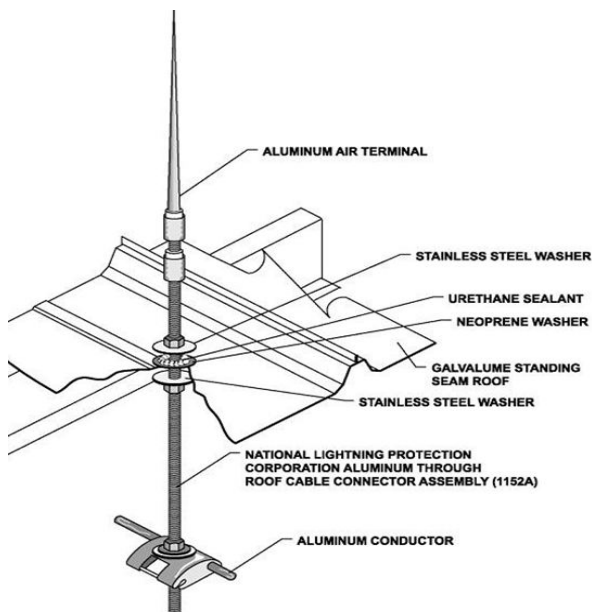

Figure 8-28  
Installation Detail Of Lightning Rod

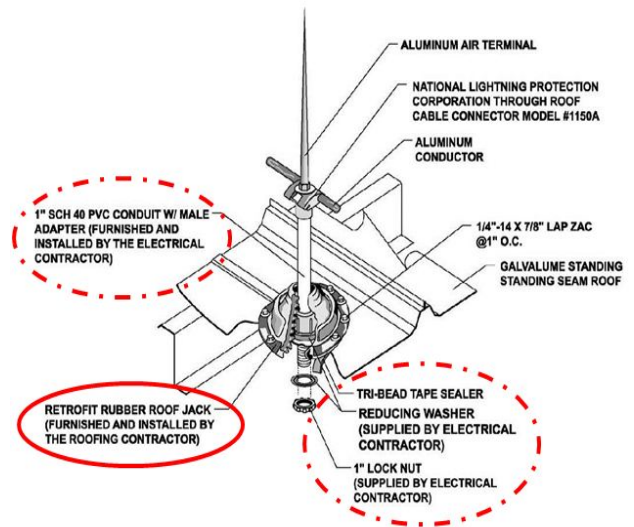

Figure 8-29  
Another Example of Lightning Rod Installation  
Note - Designated Responsibilities

Caution should be used when installing Lightning protection to avoid double pinning of roof panels and interfering with thermal movement.

Exposed copper lightning hardware, rods, or wiring should never be used on roofs or materials not compatible with copper, such as steel, aluminum, and zinc. More information on lightning protection can be found in the MCA Technical Bulletin "Lightning and Metal Roofing".

**8.8 Solar and Photovoltaic Systems**

Metal roof systems provide an ideal platform for emerging renewable energy technologies, like solar-thermal (heating of water) and photovoltaics (or PV). Photovoltaic technologies capture, collect, and convert the sun's energy into electrical energy. (See Figure 8-30) In the northern hemisphere, the best orientation for solar devices faces southward and is clear of any shading or obstructions.

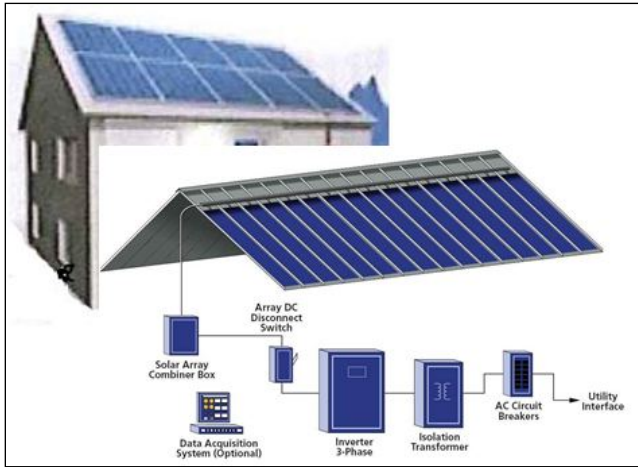

Figure 8-30  
Roof Mounted Solar Energy Systems

The relatively light weight of a metal roof, when compared to traditional roofing materials, normally allows the existing roof structure to support the additional weight of solar energy systems with little or no modification. In many cases, the weight of the metal roof *plus* the additional weight of the solar energy components is still less than the original load limit of the roof!

There are currently two major methods of installing roof-mounted solar energy and photovoltaic systems. This is a rapidly developing area. Variations and new methods are being developed on a regular basis.

Currently, one method involves separate field-installed components and panels. These are mounted above the metal roof panels with roof jacks and “racking”, or secured to roof panel ribs using a clamping device. Systems using this method mount separate “solar panels,” similar to the ones shown in Figure 8-31 on the roof. The size and number of these panels will depend upon the desired power output of the system, the geographical location of the site, and the structural orientation in relationship to the sun.

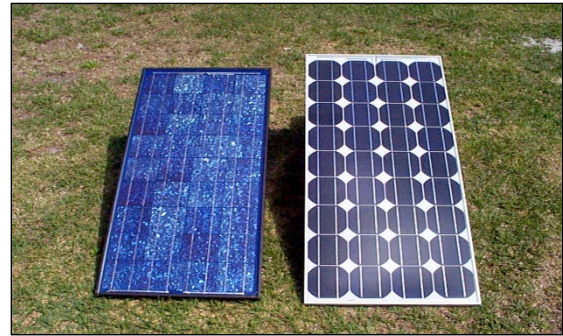

Figure 8-31  
Solar Panels Ready for Roof Mounting

The clamping and mounting devices for these panels are usually provided by the manufacturer of the solar equipment, or third parties, but sometimes also by the roof system manufacturer. Figure 8-32 shows one such example of a universal mounting clamp.

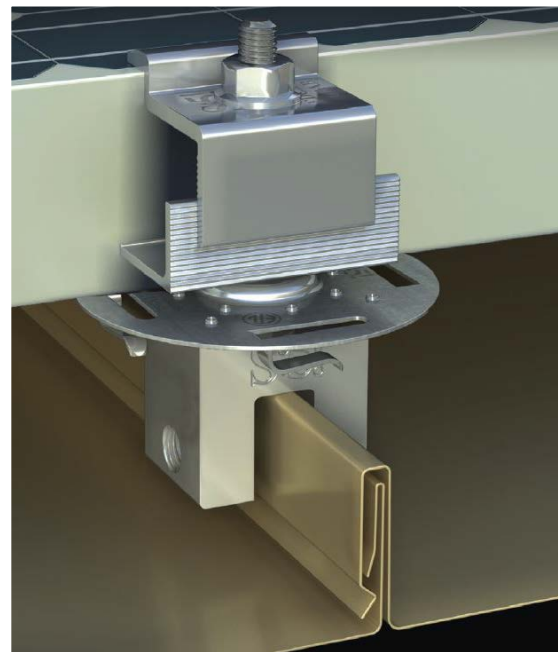

Figure 8-32  
Third Party Universal Mounting Clamp/Hardware

Whenever possible, mounting should avoid puncturing the roof panel thereby creating an opportunity for leakage. If through-panel fasteners are used, consideration must also be given to double-pinning and thermal movement issues.

The other method currently in use includes thin film, or a type of BIPV (Building



Integrated PhotoVoltaics) laminated material attached to the flat, drainage pan surface of the roof panel itself. Figure 8-33 shows the location of the material and several photos of BIPV thin film currently used on metal roof panels.

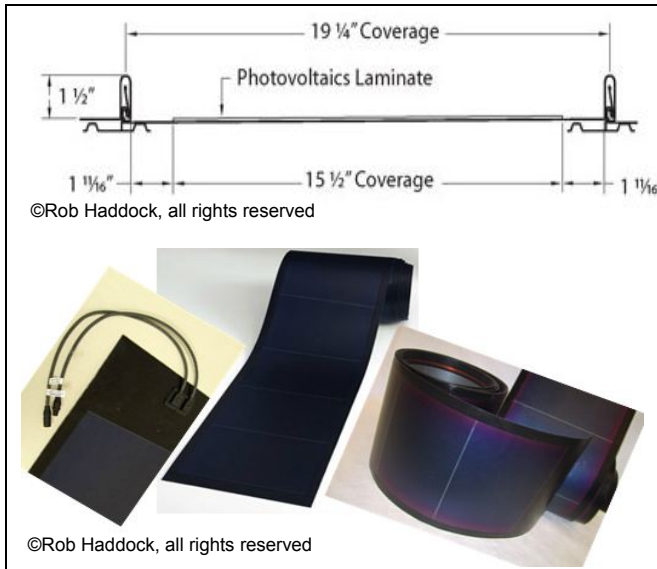

Figure 8-33  
BIPV Laminated Thin Film

There are roof system manufacturers who offer a solar/photovoltaic option on their systems, and apply the appropriate photovoltaic components at the time the roof panel is formed. Other systems apply a "photovoltaic laminate" in the appropriate locations after the roof system is in place. Either method provides a neat, attractive, and environmentally friendly installation like those in Figure 8-34.



Figure 8-34  
Photovoltaic Laminate on a Metal Roof

It is unlikely the roofing installer will be involved directly in the installation of the separate solar or photovoltaic system unless the solar panels are an integrated part of the roof panel, or the installer has received special training in the installation of such specialized systems. The installation of any solar or photovoltaic system, however, will affect an installer's "normal way of doing things." An installer may need to alter both the *way*, and *where* walking is permitted on the roof surface in order to avoid damaging any installed solar panels or components. Previously installed solar components produce tripping hazards, and may also prevent an installer from making repairs or installing necessary fasteners, trim, or closures.

Any adhesive used to attach these solar panels or components to the roof must be compatible with the roof panel's finished surface for proper adhesion. Care must also be taken to assure that any additions to the roof panel do not void the roof system's warranty.

### Chapter Summary

In closing, an installer must remember several important points from this chapter.

This chapter deals exclusively with common roof accessories, not necessities. Depending on the specifics of each job, the geographic location where the installer normally works, or type of installation performed (residential or non-residential), some, or none, of the mentioned items may be used.

The accessories mentioned may be added to the roof system during any portion of the roof life cycle, not just at the initial installation. These accessories may be installed by other members of the roofing trade; members of another trade, such as HVAC or electrical tradesmen; or even non-tradesmen of unknown skill levels, perhaps by the owners themselves. Those installing

