

Qualifying Snow Retention Systems for Metal Roofing



OVERVIEW

Metal roofs provide durable, long-term solutions and have been preferred by many for use in challenging northern and alpine climates where snow and its migration on and from the rooftop is a normal occurrence. Such climates can pose unique challenges for any roof. A pitched roof of a material that has a slippery surface can pose sliding snow and ice hazards below the eaves. In many instances, snow retention systems are installed on these roof types in order to reduce the risk of a sudden rooftop avalanche and mitigate the hazards present in the discharge areas below the eaves.

Snowpack, or the buildup of snow and ice, on any roof can produce significant sliding forces. Sudden release from a rooftop can dump tons of snow below the eaves in a matter of seconds, endangering building elements, landscape, vehicles, and pedestrians. In this sense, the use of snow retention devices and systems should be considered nothing less than a life-safety issue. In most alpine regions of Europe and Scandinavia, the use of snow guard systems is mandated by building authorities,

however such policy in North America is quite rare and only required by local code authorities if at all.

Although there is no harmonized standard for the design and testing of snow retention systems, these systems can (and should) be prudently tested, engineered, designed, and proven to resist the forces induced by the snowpack on a site-specific and roof-specific basis. When basic engineering principles are not followed, failure of the snow retention system can occur resulting in property damage and potential loss of life. With the lack of specific direction in the codes, standards of practice, and testing requirements, products offered in the marketplace may not perform adequately to save property and lives.

Users are left in a “buyer-beware” position to make decisions with only technical information that may be beyond their comprehension from the specific snow retention system vendor. This technical bulletin has been created to help building owners, users, contractors and designers qualify and select products and systems that are:

- Engineered and designed in accordance with project specifics;

- Proven through testing to withstand the intended design loads using certified products that are exactly the same as those used in the field;
- Produced in a controlled, audited facility with quality standards to assure product consistency; and
- Able to sustain their integrity for the anticipated roof service life or longer.

Two technical bulletins have been published by the Metal Construction Association (MCA) that may provide additional information in this subject area. “**Metal Roof Design for Cold Climates**” and “**Fastener Compatibility with Profiled Metal Roof and Wall Panels**” are available through the MCA website, www.metalconstruction.org/Tech-Resources. These documents support the content presented here and should be consulted for further information concerning the calculation of snow loads and forces presented by sliding snow, metallurgical compatibility, and other related information.

DEFINITIONS

Snow Guard: (Syn: Snow Stop, Snow Break, Snow Block, Snow Rail) A generic term used for any device or system that functions to retard or restrain sliding snow. Snow guards do this by utilizing the compressive strength and density of the snowpack immediately adjacent to the roof surface, thereby resisting the vector force of snow for a specific tributary area of the roof. Due to the many varied properties involved with snowpack, no snow guard or system can assure 100% effectiveness. When properly designed, manufactured, and installed the snow guard can mitigate most of the dangerous effects of sliding snow and greatly reduce the risk of a roof-top avalanche.

Unitized Snow Guard: (Syn: Discontinuous Snow Guard, Snow Cleat, Pad Style Snow Guard,) A unitized snow guard may be single or multi-component and does not utilize a continuous cross-member for purpose of snow retention. Unitized snow guards are normally used in a redundant

fashion across a roof surface and rely on the “bridging” of snowpack to span between adjacent devices to limit snow migration between the devices.



Unitized Seam-Mounted Snow Guard

Continuous Snow Guard: (Syn: Rail Type Snow Guard, Snow Fence, Snow Rail, Pipe-Style Snow Guard,) A snow retention system that, at a minimum, has two components: 1) brackets or seam clamps anchored to the roof and 2) cross-members anchored to the brackets or clamps that restrain sliding snow. A continuous snow guard system may involve one or multiple cross-members.



Snow Retention System: (Syn: Snow Guard System) A series of unitized snow guard devices or continuous assemblies installed for the purpose of retaining snow on a roof allowing the snow to evacuate slowly via thaw and sublimation rather than suddenly and unexpectedly via rooftop avalanche.

© 04/2023

METAL CONSTRUCTION ASSOCIATION

8735 W. Higgins Road, Suite 300, Chicago, IL 60631

847.375.4718 | mca@metalconstruction.org | www.metalconstruction.org

BUILD LEGACIES
 METAL

Design Roof Snow Load: The maximum seasonal snow using a 50-year mean reoccurrence anticipated to accumulate *on a roof* measured in psf. of vertical load (P_f or P_s). Snow loads measured *on the ground* (P_g) are mapped and defined by building codes and engineering standards. When taken to the roof level, the ground snow load must often be modified as instructed by the same codes and standards. In many cases involving low-slope or flat roofs (P_f), the snow load is reduced due to natural wind scouring and thermal factors. On steeper roofs or warm roofs, the snow load may be reduced still further (P_s). In other cases, the snow load is increased due to wind conditions or a wind-driven snow surcharge (such as on the leeward side of a ridge). “Aerodynamic shade” (the result of drifting due to higher adjacent walls and roofs) or some thermal coefficients on cold roofs may also increase the snow load.

In any case, a building structure that is designed in accordance with the current building codes and standards is presumed to be engineered to withstand design roof snow loads. The sole exception is an unobstructed “slippery surface” roof load reduction as defined in ASCE 7-16, Section 7.4 and Commentary Section C7.9. When such a load reduction has been used in the design of the structure, the use of a snow retention system is prohibited.

Vector Force of Snow: (Syn: Sliding Force of Snow, Drag Load, Gravity Load) The force acting parallel to a sloping roof surface that results from gravity loads of snow on that sloping surface. The vector force is found by multiplying the roof design snow load by the sine of the roof angle and reducing that value by the frictional resistance between the snowpack and the roof surface. Since most metal roofs are slippery surfaces and the coefficient of friction is generally undefined, the frictional resistance factor for this situation is normally assumed to be 0.0 (no friction) in this calculation. (See Job-Specific System Design below)

Cross-member: A beam-like, primary system component of a continuous snow guard system that spans from clamp-to-clamp (or bracket-to-bracket) and is designed to restrain the snowpack and transfer the force of sliding snow into the clamp and/or bracket. Cross-members may be of various cross-sectional shapes: angles, rods, pipes, square or rectangular tubes or combinations of these geometries.

Primary System Component: The structural components of a snow retention system that function as the anchorage system transferring the vector load of the snowpack to the structure, roof covering, or another primary component. Primary system component examples include: mechanically fastened unitized snow guards, seam clamps anchored to the roof seam and cross-members, or brackets that support cross-members.

Seam Clamp: (Syn: Standing Seam Roof Clamp) A primary system component that is non-penetrating and attaches to the seam area of a standing seam or similar type of roof. This attachment is accomplished by pinching the seam in a clamping fashion using rounded point set-screws tensioned against the seam material. The seam clamp transfers load from the continuous snow guard into the panel seams.

Secondary System Component: A minor component that enhances the performance of the primary system components, particularly in fence-type systems. Examples include snow clips, cross-member splices, and unitized snow guards when used to supplement a continuous system.

Snow Clip: (Syn: Ice Flag, Snow Flag): A secondary system component that attaches to a cross-member to restrain snow and/or ice from sliding beneath the cross-member.

Splice: (Syn: Cross-member Splice): A secondary system component that joins adjacent sections of cross-members to maintain alignment and/or structural continuity. In continuous snow retention systems, the splice may also provide for the

expansion/contraction of adjacent cross-member components.

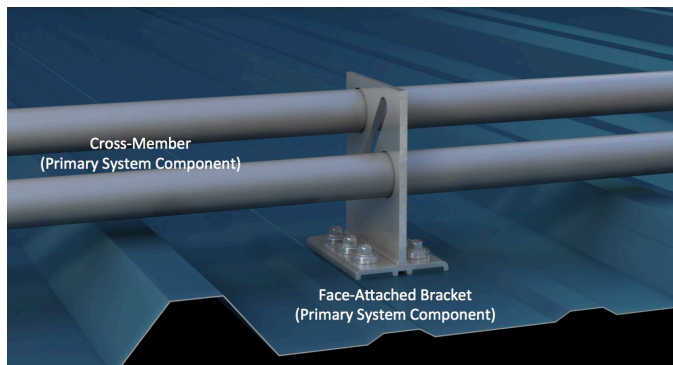
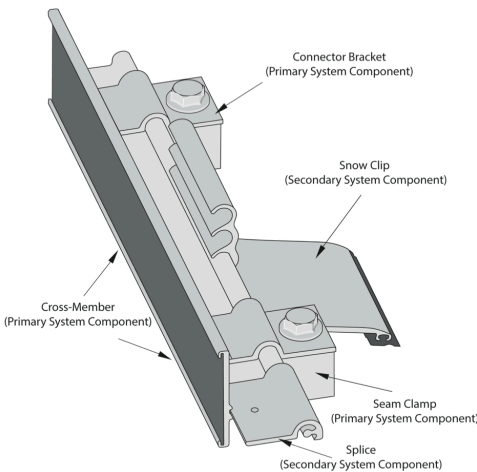
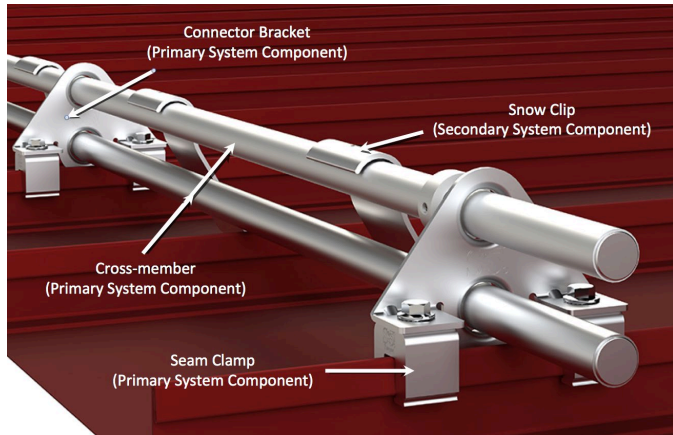

GENERAL

All snow guard systems represent a load chain to transfer the sliding forces of snow into the building structure. For proper design, each link in this chain must be proven to withstand the forces to which it will be exposed. This is not guesswork, but

a combination of testing, science, mathematics, and quality control. Proper design begins with prudent and adequate testing and/or engineering of each link in the chain, followed by the science and math to apply these results to any given project.

Finally, quality assurance is accomplished by controls and audits of production materials and manufacturing methods. This process minimizes finished product defects and variations in procedures that can compromise performance in the areas of quality, chemistry, and dimension. Products or systems that cannot provide evidence of compliance with a structured quality assurance program should be presumed as unsuitable for a life-safety application such as snow retention.

Snow guard systems should also provide durability and reliable holding strength lasting the life of the roof material. They should have no negative effects on the roofing material or negatively impact the service life. The following suggested “best practices” criteria and quality assurance measures should be helpful to both the designer and the concerned buyer in evaluating the snow guard system. These “best practices” should be incorporated into a technical or architectural specification, or simply used as a practical tool for the evaluation of a snow guard system.

MATERIALS AND SERVICE LIFE COMPATIBILITY

Primary snow guard system components, including attachment fasteners, should be fabricated from non-corrosive metals with service life expectancies at least equivalent to the roof itself. This Service life expectancy is generally in the 60-year range in most environments for unpainted 55% Al-Zn coated steel. The Service life expectancy should be longer for aluminum, stainless, titanium-zinc, and copper roofs and shorter for metal roofs that are pre-painted.

Preferred snow guard system materials for copper roofs are brass alloys. Anodized structural aluminum alloys with stainless steel (passivated)

© 04/2023

METAL CONSTRUCTION ASSOCIATION

8735 W. Higgins Road, Suite 300, Chicago, IL 60631

847.375.4718 | mca@metalconstruction.org | www.metalconstruction.org

BUILD LEGACIES
METAL

fasteners or caps should be used when portions of the fasteners are exposed to the elements and brass alloys are not commercially available. Preferred snow guard system materials for coated steel, aluminum, zinc or stainless are structural aluminum alloys or 300 series stainless steel. Stainless steel (passivated) fasteners or caps should be used when portions of the fasteners are exposed to the elements.

Plastic components have not shown the ability to remain in service for the typical expected roof service life. These products should only be used as secondary system components, or not at all.

To assure a similar expected service life, washers and sealants used for waterproofing snow guard components shall be of the same chemistry and equal durability as the washers and sealants present in the roof system itself. Isobutylene/isoprene (butyl) polymers or materials with similar or greater service lives are generally recognized as preferred sealants. Ethylene propylene diene monomer (EPDM) or materials with similar or greater service lives are the preferred washer/gasket chemistry, utilizing carbon black UV stabilizers. Sealing materials shall be used in such fashion and location as to protect the material from direct exposure to sunlight (e.g., as gaskets beneath and between metallic components). Some means of preventing over-compression of the gasket material should also be provided.

Compatibility of all metal attachments, interfaces and related fasteners should comply with the MCA Technical Bulletin *Fastener Compatibility with Profiled Metal Roof and Wall Panels*. Snow retention systems for standing seam roof installations should be mechanically attached to panel seams via seam clamps with only limited exceptions. Snow guards utilized on face attached roof systems shall be installed using direct or bracket components that are mechanically attached through the panels to the underlying substrate or building structure.

Extruded structural grade aluminum components shall be of 6000 series and compliant as appropriate with the following ASTM standards:

- ASTM B 221 Specification for Aluminum and Aluminum-Alloy Extruded Bars, Rods, Wire, Profiles and Tubes
- ASTM B 308/B 308 M Specification for Aluminum-Alloy 6061-T6 Standard Structural Profiles
- ASTM B597 Practice for Heat Treatment of Aluminum Alloys
- ASTM B807 Practice for Extrusion Press Solution Heat Treatment of Aluminum Alloys

Cast aluminum components shall be compliant with one of the following:

- ASTM B26/B26M Standard Specification for Aluminum-Alloy Sand Castings
- ASTM B108/B108M Standard Specification for Aluminum-Alloy Permanent Mold Castings
- ASTM B85/B85M Standard Specification for Aluminum-Alloy Die Castings

Plate and sheet aluminum components shall be compliant with:

- ASTM B209 Standard Specification for Aluminum and Aluminum-Alloy Sheet and Plate

Brass components shall be compliant with:

- ASTM B927/B927M Standard Specification for Brass Rod, Bar, and Shapes

Stainless Steel Components shall be 300 series alloy with minimum 18-8 content of nickel-chrome and compliant with:

- ASTM A276/A276M Standard Specification for Stainless Steel Bars and Shapes

JOB-SPECIFIC SYSTEM DESIGN

Snow retention systems shall be engineered to the specifics of each roof surface and installation for structural capacity to resist the vector forces of sliding snow. These forces shall be computed as described in the MCA technical bulletin *Metal Roof Design for Cold Climates*, or by a licensed design professional. Evidence of such engineering shall be provided to the buyer prior to the start of construction. All computations shall be supported by appropriate, detailed calculations.

Job-specific calculations shall be supported by test data showing the holding strength of the primary system components that are mechanically attached to standing seams (in the case of standing seam roofs) or through the roof panels to the building structure (in the case of face fastened roof panels). Testing must be specific to the project roof surface (or substructure).

Components that attach through the roof panels to the building structure may not be used on standing seam profiles, unless the attachment is proven to enable free thermal panel response along their length. Products utilizing non-mechanical adhesive systems are not recommended for primary system components on any metal roof type. Non-mechanically attached systems may not be compatible with a variety of coatings or paint systems applied to metal roofing. In addition, adhered products have not demonstrated, through test results, the required long term adhesive strength required by the structural calculations for the roof service life. For these reasons, non-mechanically fastened snow retention systems are not recommended in this document.

Cross-members of continuous systems shall be either lab-tested or engineered to show adequate buckling strength (Yield) along a uniformly loaded span consistent with the project requirements.

Unsupported cantilevers and splices of cross-members, as well as cross-member brackets, shall be either lab-tested or engineered to show project-

compliant performance. Continuous snow retention systems that contain splices or expansion joints shall be designed to enable a thermal response to a delta temperature (ΔT) of 200°F. Details of these connections shall be clearly identified in the seller's installation instructions.

Calculations shall bear the project name and location, the name of the snow guard system manufacturer and any nomenclature specific to the snow guard system and its components.

In the case of face-attached snow guard systems, the submitted calculations shall reference the performance of the specific substrate to which the primary system components are attached (e.g., 5/8" plywood deck, 15/32" O.S.B, white pine 2' dimensional purlin, 16-gauge steel purlin, 22-gauge steel deck, etc.). Calculations shall be supported by lab test data of the specific primary snow guard system components proposed for the specific project substrate utilizing the same fastening type and frequency as tested.

In the case of standing seam profiles, the calculations shall identify the specifics of the roof profile including the profile manufacturer, material type, gauge thickness, profile identification and nomenclature, and test protocol used to obtain the design information. Test results for any specific roof panel profile, manufacturer, material type, or gauge thickness may not be substituted for another except for cases where the identical profile is produced using identical material specifications and forming equipment under the licensure of the primary manufacturer.

Allowable loads for seam clamps or unitized snow guards that mechanically attach to standing seams or directly to the structure shall be reduced from tested ultimate failure load by a minimum Factor of Safety (FS) ≥ 2.0 and compliant with local building codes when utilized in computations.

For recommended "Testing and Engineering" procedures, see that subheading within this document.

© 04/2023

METAL CONSTRUCTION ASSOCIATION

8735 W. Higgins Road, Suite 300, Chicago, IL 60631

847.375.4718 | mca@metalconstruction.org | www.metalconstruction.org

BUILD LEGACIES
 METAL

SNOW GUARD PLACEMENT

Snow guard placement is a key factor in effective snowpack retention design and should be well thought out and prescribed by the system designer. To properly locate and space rows of snow retention, the designer must have a clear understanding of roof geometries, how snow accumulates and how snow behaves on a metal roof. Snow guard placement is not a decision based on pure science; however, there are guidelines to aid in the design. The MCA technical bulletin *Metal Roof Design for Cold Climates* is a good reference guide for snow retention calculations and placement.

As a general guideline, the entire eave line of a building should be protected, rather than an isolated area of the roof. The amount of force acting on a short section of snow guards on a large roof is very difficult to accurately estimate. Placing snow retention over limited areas such as doorways is potentially a dangerous practice. (*Metal Roof Design for Cold Climates*; Figure 12) When the entire eave is protected, shorter sections of snow guard can be used upslope of roof elements, such as flues if desired for added protection of rooftop appurtenances.

When more than one row of snow retention is necessary based on design calculations, spacing considerations come into play. On a stand-alone, unobstructed sloped metal roof, snow tends to accumulate, densify, and migrate resulting in somewhat greater concentration near the eaves. (*Metal Roof Design for Cold Climates*; Figure 11). Snow accumulation effects are complex and snow retention placement and spacing must be considered on a job-specific basis, using design methodology, common sense, and basic guidelines when applicable.

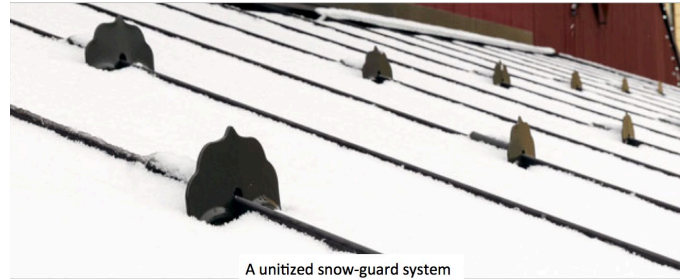

MANUFACTURING QUALITY ASSURANCE

All primary and secondary system components that perform a structural function shall be manufactured from mechanically and chemically certified material. The snow retention system seller shall provide product and production certification information including traceability and lab reports to the buyer upon request.

All primary system components of a snow retention system shall be manufactured in an ISO 9000/9001 facility or an IAS certified facility with a Total Quality Management (TQM) program in place. The seller shall furnish evidence of certification to the buyer upon request.

TESTING AND ENGINEERING

Snow guard systems must be proven structurally adequate by appropriate mechanical load testing and/or engineering evaluation. Primary system components must be load tested individually. The load capacity of the snow retention system may be proven by supplemental engineering evaluation, based on the weakest primary component determined from load testing. A snow guard system can only be engineered with prudent and complete test data on all components of the system.

Lab Qualification and Pre-Test Information

The laboratory where the primary components testing takes place must be a Nationally Recognized Testing Laboratory (NRTL) that is ISO 17025 accredited unless otherwise stipulated by the local authority having jurisdiction. The following

© 04/2023

METAL CONSTRUCTION ASSOCIATION

8735 W. Higgins Road, Suite 300, Chicago, IL 60631

847.375.4718 | mca@metalconstruction.org | www.metalconstruction.org

BUILD LEGACIES
 METAL

supporting documents and information should be provided prior to testing:

- Installation Instructions: Must be consistent with those published for use in the field or the job specific engineering design and followed carefully for specimen preparation.
- Product identification: The manufacturer or report holder's name, address, specific product name(s) and model, including ID number (if applicable) shall be located on the product packaging.
- Tested samples (Primary Component): Representative of the actual product to be used.
- Tested samples (Panel Seam Specimen): As provided by the metal roof panel manufacturer from the standard product offering and assembled into a finished seam utilizing the same methods and equipment as prescribed by the manufacturer. Mill certification for the coil utilized must be provided, or material properties verified by tensile testing per ASTM E8.

Testing

Seam Clamps – The clamp-to-seam connection is a critical link in the load chain and should be isolated for testing. Metal roof panels are offered in many profiles, materials and thicknesses, and each variable can provide different test results. This specific test information is critical for job-specific engineering calculation. Standing seam clamps tested should be geometrically and metallurgically compatible with metal roof seam profile and material.

The metal roof panel sample shall be tested using a universal test machine complying with ASTM E4 with the load path directed parallel to the roof surface. The test shall be conducted using a minimum of three samples and utilizing a “fresh” clamp for each pull. Multiple pulls can be performed on a single metal roof panel test specimen, provided it is of sufficient length to utilize an undamaged section for each test. The

failure criteria for this test include any of the following conditions:

- A. Dis-engagement of the clamp and panel seam
- B. Clamp displacement of more than 8 mm (.315")
- C. Breakage or fracturing of the clamp or fasteners
- D. Stripping or other failure of any related fasteners
- E. Fracturing of any area of the panel seam
- F. Buckling or any other structural or severe cosmetic damage to the panel seam

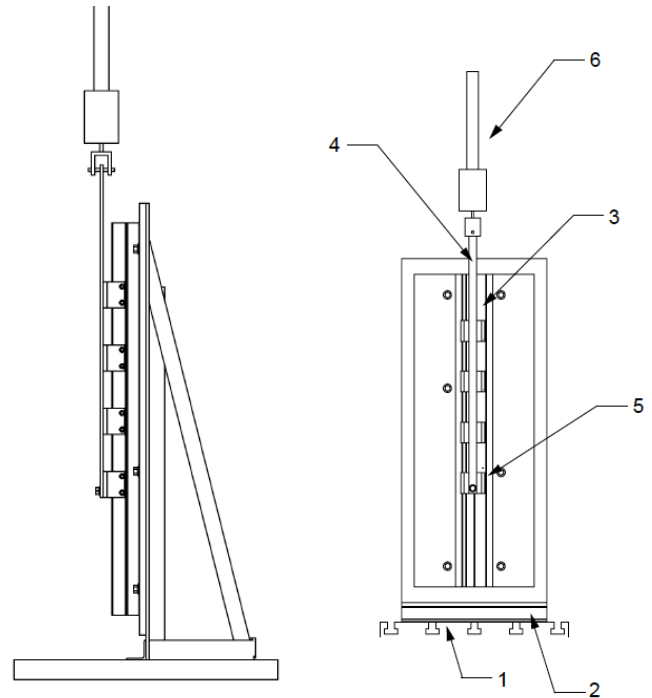

Cross-members – Cross-members shall be analyzed using beam strength calculations, point load testing or distributed load testing. If the snow retention system utilizes a splice to connect two adjacent cross-members, load testing shall be performed on the splice connection centered over the largest allowable span. If no splice is used, load shall be applied to the cantilevered portion, which is the full distance of the seam spacing on the project being considered.

Unitized Snow Guards – Only unitized snow guards employing a mechanical connection to the roof should be used to ensure long term performance. Unitized snow guards using seam clamps should be tested, following the procedure for seam clamps with the following modifications:

- Mount the unitized snow guard on the seam clamp and apply load to the face of the snow guard.
- To replicate non-concentric loading conditions, apply load as far as possible from the centroid along the x-axis of the snow guard, inducing a “left to right” moment arm.
- Other aspects of clamp testing are the same.

Unitized snow guards that are not seam mounted, but attach directly into the structure (such as face-attached roof types) shall be tested in similar fashion utilizing the same fasteners as prescribed by the manufacturer’s installation instructions.

Brackets (when used as a primary system component of rail systems)

Brackets, mounted either directly to the metal roof or connected to a seam clamp, are primary system components and should be tested accordingly. Following a procedure similar to the seam clamp test, mount the brackets as they would be in the field and apply load to the point where the cross-member is inserted. In the case of multiple cross-members, apply load to the point where the highest

cross-member is inserted. Failure occurs under one or more of the following criteria:

- A. Bracket rotated more than 20 degrees
- B. Yielding of bracket-to-substrate connection
- C. Visible, permanent deformation of the bracket, including bending or tearing

Reporting

Reporting for either clamp or bracket testing should meet (at minimum) the requirements of ASTM E575

- Name of roof material provider (manufacturer)(clamp assemblies only)
- Name of profiler (if different than the roof material provider)(clamp assemblies only)
- Nomenclature of specific profile tested (clamp assemblies only)
- Profile material including decimal thickness or gauge (clamp assemblies only)
- The substrate or structure type and thickness or gauge (unitized snow guards or bracket assemblies for face-attached roof types)
- Fastener type, material, and quantity (unitized snow guards or bracket assemblies for face-attached roof types)
- The mode of failure and load at failure along with a brief description
- The force vs. displacement should be graphed and overlaid with each successive pull for an individual test. The average ultimate load at failure should be calculated along with the standard deviation and coefficient of variance.

Applying the Data

Appropriate testing of each link in the load chain allows the system designer or producer to propose a fully engineered system. The connection to the roof, the connection of the cross-members to a bracket or seam clamp, and the strength of the cross-members

are all evaluated. The system's structural capacity is found by the identification of the weak link within the load chain and the application of appropriate factors of safety to that link. Component test results and engineering evaluation is now used in conjunction with site-specific data such as roof design snow load and dimensions, to provide a basis for determining structural adequacy on any given project. System population (frequency) should be equal to or exceed calculated in-service loads.

INSTALLATION

Snow guards must be installed per the manufacturer's installation instructions. Determine frequency and placement prior to installation. System components may be preassembled to the extent possible before commencing installation.

To ensure straight rows of snow retention, determine a reference point at either end of the intended row by measuring from the eave. Attach a string line – one end to each reference point – and mount the remaining clamps along this line. When installing seam clamps, ensure that the manufacturer's prescribed set screw torque is met. Tightening to the recommended torque is critical when relying on published load values. This is normally accomplished by calibrating the tightening tool to the desired screw tension. Periodic checks must be completed to ensure the tool remains correctly calibrated. (Note: Most applications are "soft joint," Clicker torque wrenches commonly available on the market are not generally suitable for soft joint applications. Dial-indicating torque wrenches are strongly preferred.)

For exposed-fastener applications, ensure that the fasteners used to secure the system to the roof are equal or superior, in terms of expected service life, to the fasteners used/recommended by the roof system manufacturer. Load values published for exposed-fastener products are only relevant if the same fastener is used both in testing and on the job. Fasteners are also substrate specific. The ideal fastener for attachment to a steel purlin is different

than the fastener used for dimensional timber or wood deck construction. If the snow guard manufacturer cannot provide specific substrate testing using a particular fastener, the data is not applicable to the project.

Install cross-members to complete a continuous snow guard system. If a multiple cross-member system is used, make sure to offset splices (e.g., the top cross-member should not be spliced over the same span that the bottom cross-member is spliced). Be sure to install secondary components, such as end caps, collars, and snow clips per the manufacturer's installation recommendations. These components are often critical to the function of the system and should not be overlooked.

Reading and following the manufacturer's provided installation instructions is key to a successful installation and the performance of the completed system. Plan the layout and placement prior to installation. Take care that rows are straight and the set screws are correctly torqued. If fastening to the structure, be sure to use the manufacturer's tested fasteners only.

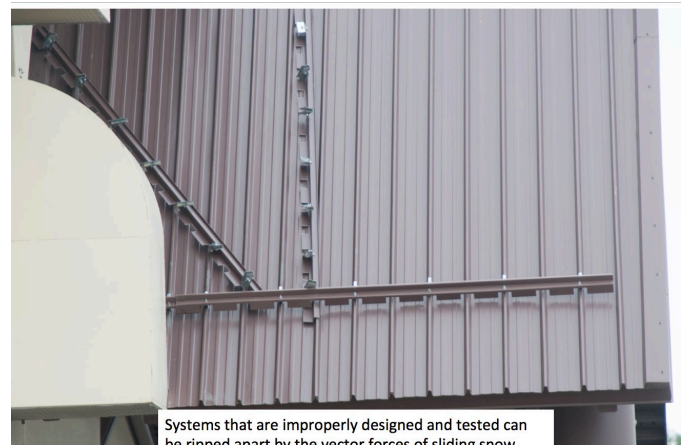

Systems that are improperly designed and tested can be ripped apart by the vector forces of sliding snow

Founded in 1983, the Metal Construction Association brings together the diverse metal construction industry for the purpose of expanding the use of all metals used

© 04/2023

METAL CONSTRUCTION ASSOCIATION

8735 W. Higgins Road, Suite 300, Chicago, IL 60631

847.375.4718 | mca@metalconstruction.org | www.metalconstruction.org

BUILD LEGACIES
METAL

in construction. MCA promotes the benefits of metal in construction through:

- Technical guidance
- Product certification
- Educational and awareness programs
- Advocating for the interests of our industry
- Recognition of industry-achievement awards
- Monitoring of industry issues, such as codes and standards
- Research to develop improved metal construction products
- Promotional and marketing support for the metal construction industry
- Publications to promote use of metal wall and roof products in construction

For more information, please visit the MCA Web site at www.metalconstruction.org

Copyright © 2023 Metal Construction Association. All rights reserved.

No part of this publication may be reproduced in any form or by any means, including photocopying, or utilized by any information storage or retrieval system without permission of the copyright owner.

This document is for general information only. The document is designed to delineate areas requiring consideration. Information contained in the document should not be used without first securing competent advice with respect to its suitability for any given application. MCA does not assume responsibility and disclaims any representation or warranty, express or implied, that such information is suitable for any general or particular use. Anyone making use of the document assumes all liability resulting from such use.

The existence of the document does not in any respect preclude a member or nonmember of MCA from manufacturing, selling, or specifying products not conforming to the document, nor does the existence of an MCA document preclude its voluntary use by persons other than MCA members. The document does not purport to address all safety problems associated with its use or all applicable regulatory requirements. It is the responsibility of the user of the guideline to establish appropriate safety and health practices and to determine

the applicability of regulatory limitations before use of the document.

The Metal Construction Association reserves the right to change, revise, add to, or delete any data contained in the document without prior notice.

It is the responsibility of the end user to verify the applicability of this information with the local building and fire officials.

© 04/2023

METAL CONSTRUCTION ASSOCIATION

8735 W. Higgins Road, Suite 300, Chicago, IL 60631

847.375.4718 | mca@metalconstruction.org | www.metalconstruction.org

BUILD LEGACIES
 METAL